

**Empty Bottle Inspector**  
**miho David 2**



## Empty Bottle Inspector miho David 2

Full inspection of the empty and cleaned bottle (returnable / non-returnable) between washing machine and filler:

- Individually configurable
- State-of-the-art real-time image processing on the miho VIDIOS® platform
- Up to 72 000 bottles per hour
- Installed more than 500 times worldwide
- Hygienic design
- Innovation: miho FSI, miho OpAL, miho Swing top seal inspection
- Optimized energy efficiency
- 24/7 hotline, remote maintenance, Spare parts supply for at least 15 years

made  
 in  
 Germany

Current innovations in this brochure are marked orange!



### Table of contents

<b>1</b>	<b>Product overview</b>	<b>4</b>
<b>2</b>	<b>Empty Bottle Inspector miho David 2   Basic machine</b>	<b>6</b>
	2.1 Basic machine	6
	2.2 miho VIDIOS®	8
	2.3 Sealing surface inspection RGB	9
	2.4 Base inspection	10
<b>3</b>	<b>Sidewall inspection</b>	<b>12</b>
	3.1 Dual sidewall inspection with miho OpAL	14
	3.2 Standard sidewall inspection	15
	3.3 Dual sidewall inspection with upgrade miho FSI	16
	3.4 miho FSI upgrade flange inspection	17
	3.5 Blowing device for the finish area for glass bottles	17
<b>4</b>	<b>Integrated inspection of swing top bottles</b>	<b>18</b>
	4.1 Dual sidewall inspection with miho FSI for swing top bottles	18
	4.2 Additional residual liquid detection	18
	4.3 Additional module clapper inspection	19
	4.4 Bottling plant swing top bottles	20
<b>5</b>	<b>Integrated inspection of returnable PET-Bottles</b>	<b>22</b>
	5.1 miho Bottle Dryer	23
	5.2 Bottling plant returnable PET bottles	24
<b>6</b>	<b>Examples of bottling plants</b>	<b>26</b>
<b>7</b>	<b>Network integration &amp; production data acquisition</b>	<b>29</b>
<b>8</b>	<b>Upgrade modules</b>	<b>32</b>
	8.1 Inner sidewall inspection	32
	8.2 Standard thread inspection	32
	8.3 Extension of visual angle for the base inspection	33
	8.4 UV Filter detection of bottles	33
	8.5 Automatic adjustment when changing bottle type	33
	8.6 Undervoltage supply	33
	8.7 Drip trays	34
	8.8 Separate computer for production data acquisition miho AWeS	34
	8.9 Separate AWeS viewer	35
	8.10 Safety cabinet	35
<b>9</b>	<b>Infeed control systems</b>	<b>36</b>
<b>10</b>	<b>Reject systems</b>	<b>38</b>
<b>11</b>	<b>Conveyor control   Conveyor construction   Container transport</b>	<b>40</b>
<b>12</b>	<b>Recommended installation   Technical data</b>	<b>44</b>
<b>13</b>	<b>Overview product range</b>	<b>46</b>

The miho David 2

and the machines at the infeed and outfeed

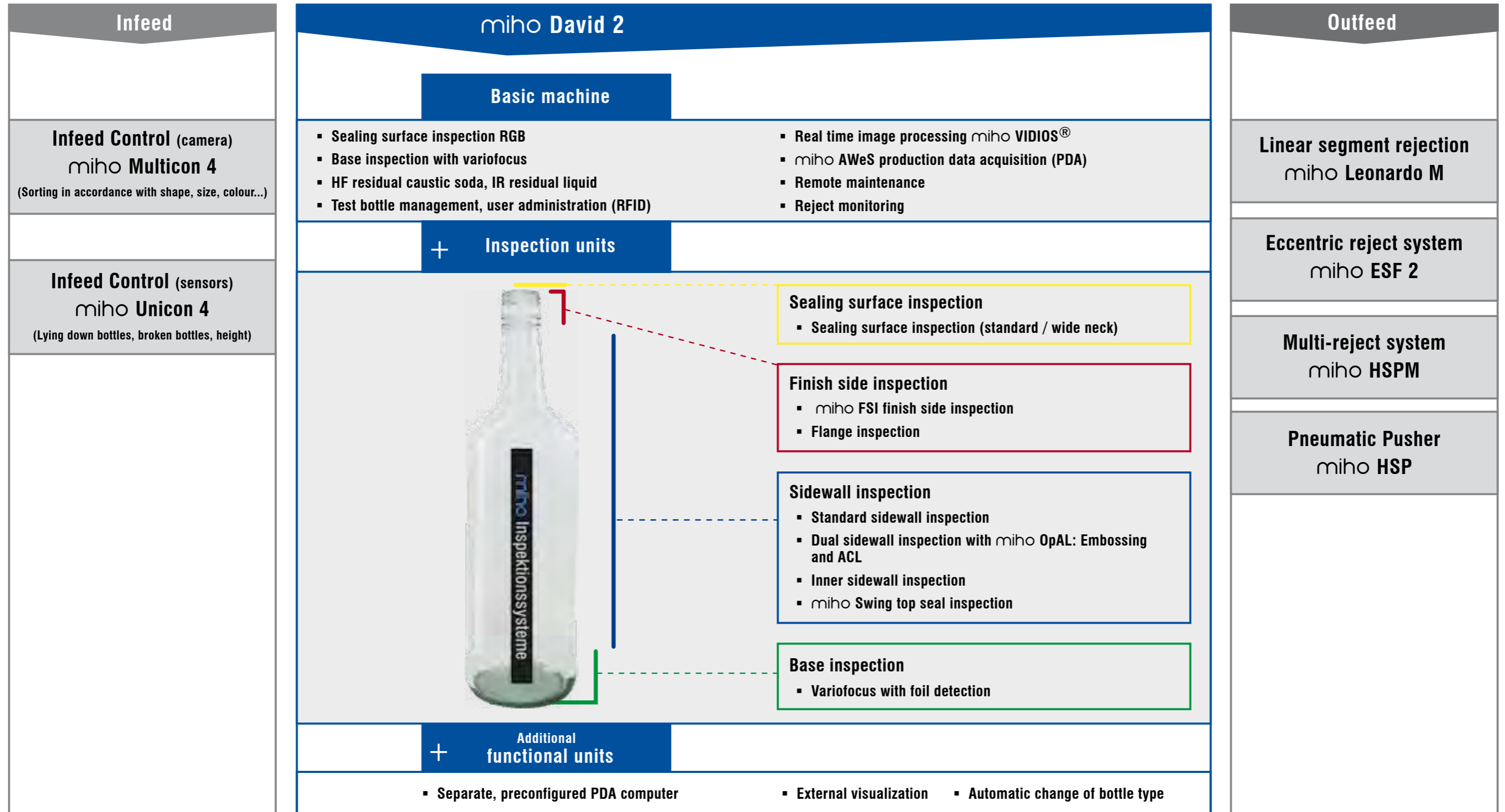

2.1 Basic machine

Function

- **Base inspection** with foil detection and variofocus: automatic adjustment of the focus for bottles with different heights
- **Sealing surface inspection** (RGB) with colour camera: detection of damage to the sealing surface
- **HF residual caustic soda AIM**: to detect liquid residues in the bottle, with continuous self-control
- **IR residual liquid AIM**: to detect organic liquid residues, with continuous self-control
- **Test bottle management**: automatic request of specially prepared test bottles to check that the machine is running smoothly. Allocation via transponder ring
- **User administration**: via transponder or password entry
- **Production data acquisition** miho AWeS with intermediate storing of production data if there is a network failure

Technology

- Real time image analysis software miho VIDIOS®
- Remote maintenance functionality with all the necessary software licences
- Software package miho AWeS for production data acquisition: Logging of all production data, counter readings, test bottle protocols and user access; Weihenstephan standard
- Mechanical construction: stainless steel, hygienic design
- TFT colour display with touch screen
- Pipeline cooling, closed system: no contamination through outside air or moisture, air conditioner based on Peltier
- Servo drive: automatic adjustment of the rotation angle (90°) for different bottle diameters
- Simple infeed protection system with line shutdown (too high, too low, lying bottles)
- Reject monitoring: line shutdown if a bottle is not rejected



Sealing surface inspection with RGB lighting



Inspection head of the basic machine, opened



Touch operation through swivel arm



Test bottle with transponder ring attached

2.2 miho VIDIOS®

- Licence-free, because the proprietary software comes directly from miho
- Intuitive graphic user interface (GUI) in the local language
- Interactive help
- Machine diagnosis with clear display of machine status
- Operating system: Microsoft Windows 10

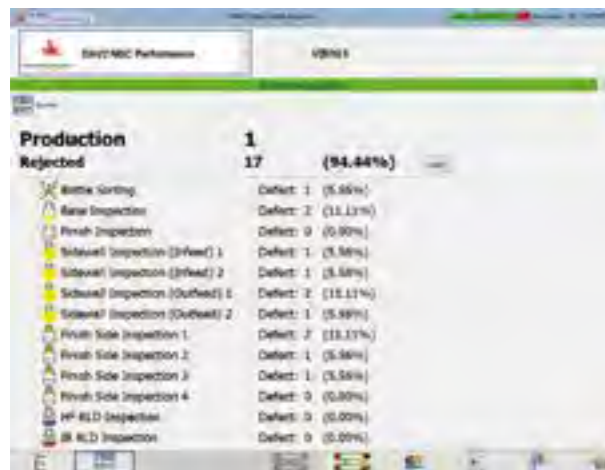

Detailed list of reasons for rejection



Icon-based user guide when changing types

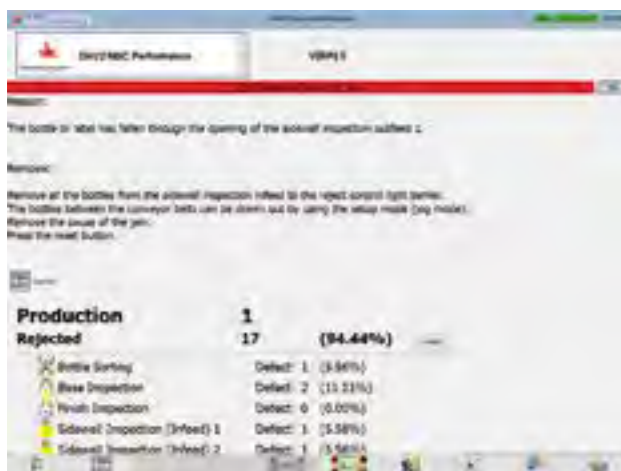

Help function in case of malfunction

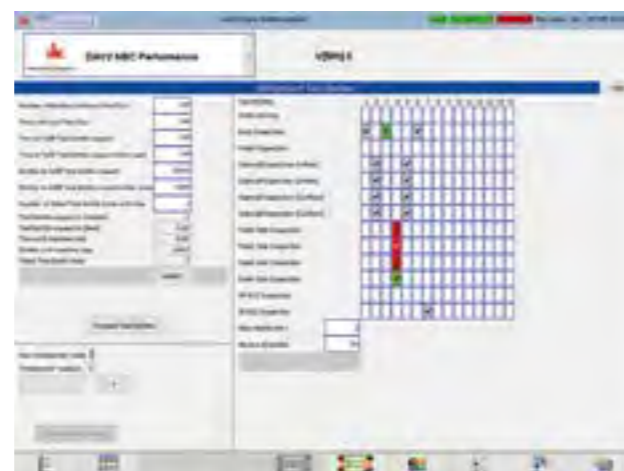

Clear presentation of the test bottle run result

2.3 Sealing surface inspection RGB

Function

- For the improved detection of damage, especially at the outer edges of the sealing surface
- Detects, for example, bursts and dirt on the sealing surface / thread
- For glass and PET

Technology

- Three lighting zones with three LED colour lighting rings RED / GREEN / BLUE at different illumination angles
- Colour camera with spectral filter



The LED colour lighting ring in operation

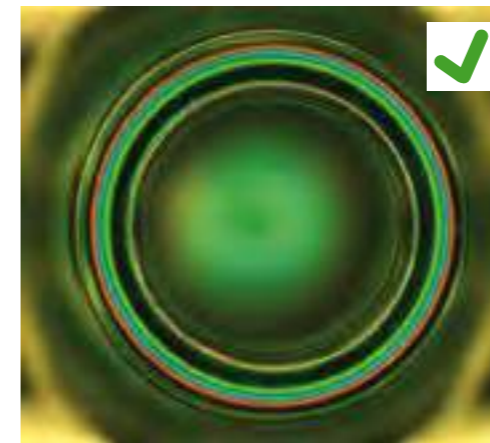

Bottle finish recorded from above with ring-shaped RGB lighting for the improved detection of chips



Glass: chip on the sealing surface

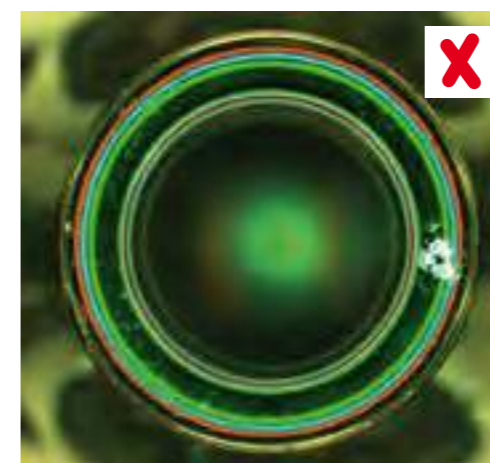

Chip on the sealing surface



Glass: chip on the sealing surface

2 miho David 2 | Basic machine

2.4 Base inspection

<b>Function</b>
Detection of:
<ul style="list-style-type: none"> <li>• Chipping, contamination, inclusions, damage</li> <li>• Foreign objects</li> <li>• Foil remains</li> </ul>
<b>Technology</b>
<ul style="list-style-type: none"> <li>• LED lighting unit below, circular pole filter, camera above</li> <li>• Variofocus: automatic focal tracking for change of bottle type</li> </ul>



Shell-shaped chipping

Base inspection also for non-circular bottles

- Configure different base shapes and set up evaluation zones flexibly
- The analysis software miho VIDIOS® now allows for a base inspection even for non-circular bottles without hidden zones
- Particularly interesting for foreign body detection in individual disposable containers



Base inspection also for base embossing

The embossing form is not recognized as an error but any contamination itself in the embossing area will be detected.



Variofocus principle:

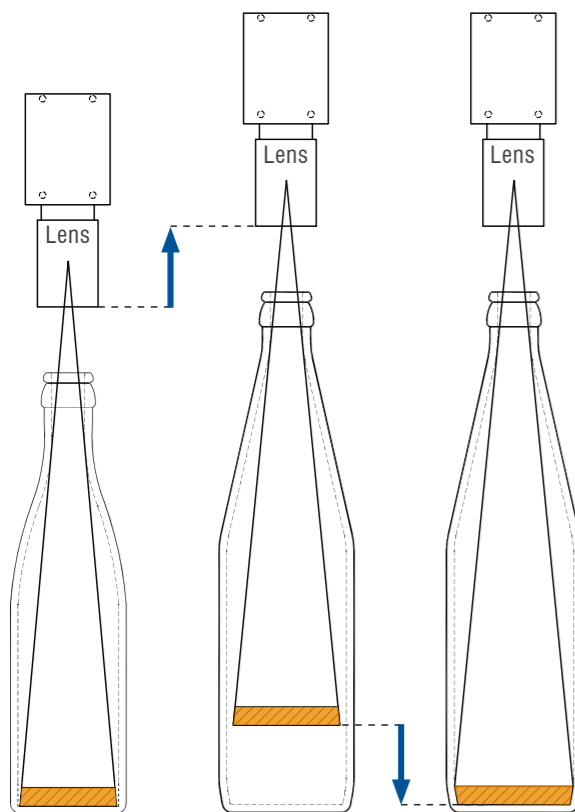

**Left:** small bottle with correct adjustment of the focus at the bottle base (orange) → sharp image

**Centre:** after changing to the big bottle, the focal point is above the bottle base, without having made any readjustment → blurred image

**Right:** miho Variofocus adjusts the focal point for the big bottle → sharp image



Cigarette foil in PET bottle

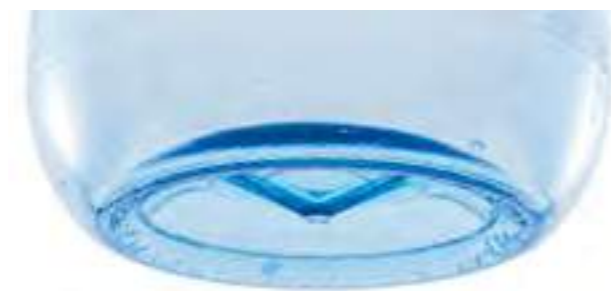

PET bottle: stress cracks

Examples of different bottles with base embossing



3 miho David 2 | Sidewall inspection in three versions

Standard sidewall inspection

- 2 high-resolution cameras
- 360° inspection
- foil detection
- meets the basic requirement of a modern full inspection



Dual sidewall inspection with miho OpAL

- 4 high-resolution cameras
- 360° inspection: fault at least once on the side facing the camera
- miho OpAL technology
- foil detection

Consider for:

- semi-transparent contaminants
- bottles with ACL labels
- bottles with relief or embossing
- swing top bottles

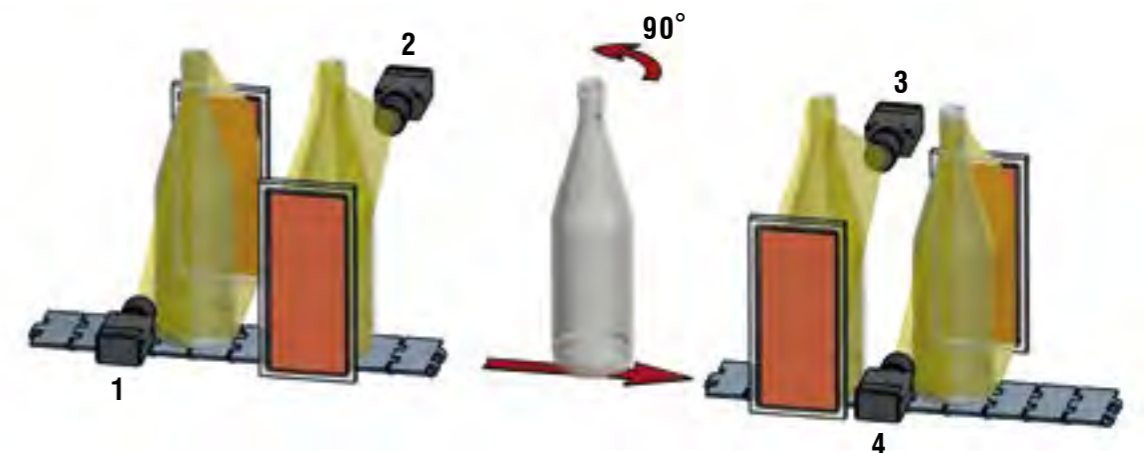

Dual sidewall inspection with finish side inspection miho FSI

- 8 high-resolution cameras
- 360° inspection: fault at least once on the side facing the camera
- miho OpAL technology
- foil detection
- Additional miho FSI: unique transmitted light method

Consider for:

- bottles with finish side damage and contamination
- bottles with finish cracks without sealing surface damage
- screw top bottles: inspection from beginning to end, from below and from above
- Damaged or dirty flanged edges

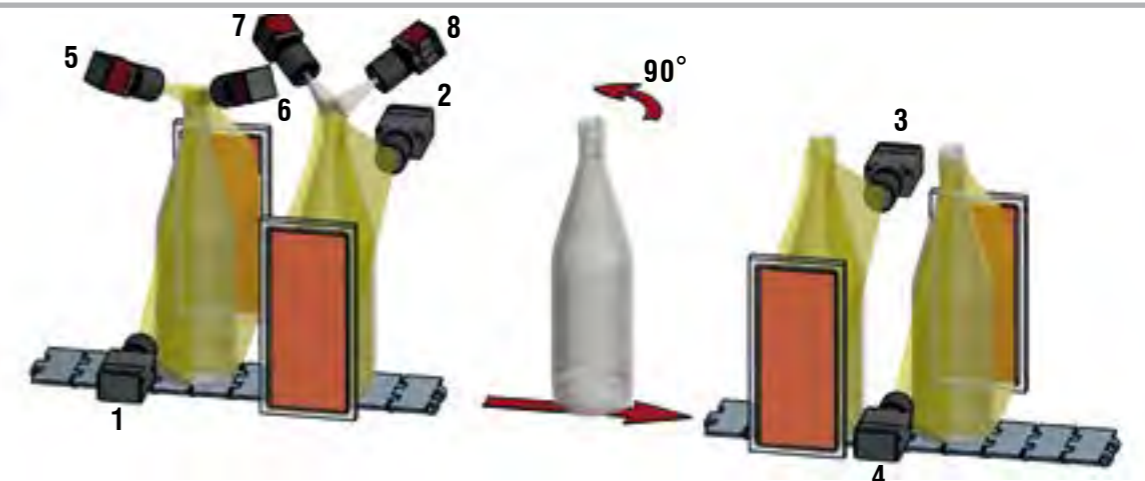

3 miho David 2 | Dual sidewall inspection with miho OpAL

Why dual sidewall inspection with miho-OpAL technology?

- **Improved sidewall inspection: glass**
  - contamination and damage of the sidewall, inclusions, ...
  - bottles with embossing and ACL labels, no masking out of the permanent areas anymore
  - swing top bottle inspection: no masking out of bracket area
- **Improved sidewall inspection: PET**
  - labelling with permanent markers
  - misted-up bottles / droplet formation
  - semi-transparent contamination

3.1 Dual sidewall inspection with miho OpAL

Function

- two modules (infeed and outfeed of the empty bottle inspector) for significantly improved detection of contamination, foil residues and damage to the outer and inner sidewall of the bottle, using a total of **four** cameras. This ensures that all areas of the bottle are recorded at least once directly from the front by one of the cameras
- especially suitable for bottles with relief structures, embossing, swing top bottles or permanent ACL labels
- defects that are difficult to detect, such as semi-transparent dirt, conchoidal fractures, or inclusions can be inspected
- **OpAL** algorithm: no concealed areas that are completely masked out by ACL or embossing anymore

Technology

- dual sidewall inspection with one module at the infeed and at the outfeed of the empty bottle inspector respectively
- **two** cameras in the infeed module and **two** cameras in the outfeed module
- two images per camera through mirror cabinet
- including circular pole filter to detect adherent foils on the inside of glass bottles



Shell chipping in decorative area

Contamination in the bracket

Chipping

Foil in the neck-area

miho OpAL

(Optimized Area Localisation) is an innovative development of the image analysis software miho VIDIOS®, used in the dual sidewall inspection. From now on, objects such as ACLs, embossing, shadows of bottle reliefs or parts of a swing top closure are recognized as such and no longer lead to false rejects. The **entire** sidewall of the bottle is inspected from now on!

Advanced inspection by miho OpAL:

Without miho OpAL

Bracket area:  
masked out

Embossing:  
limited inspection

ACL:  
masked out

Semi-transparent fault:  
limited inspection

With miho OpAL

Bracket area:  
inspection ✓

Embossing:  
inspection ✓

ACL Labels:  
inspection ✓

Semi-transparent fault:  
inspection ✓



3.2 Standard sidewall inspection

Two modules (infeed and outfeed of the empty bottle inspector) for the detection of contamination, foil residues and damage to the outer and inner sidewall of the bottle, using a total of **two** cameras.



3 miho David 2 | Dual sidewall inspection with miho FSI

Why dual sidewall inspection with miho FSI-technology ?

miho FSI (Finish Side Inspection), an upgrade of the dual sidewall inspection, allows for the complete inspection of the side finish and thread:

- dirt and damage
- rust ring detection
- cracks
- inspection regardless of the thread form
- no false rejection of refunded new bottles



Twist-Off: Thread defect



Twist crown: Chipping at the flanged edge

Twist-Crown: Thread defect

Twist crown: vertical split

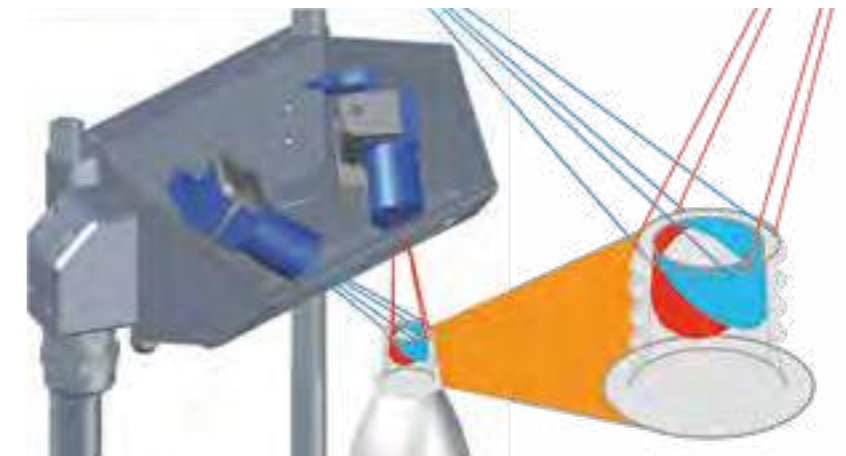

miho FSI schematic view: the cameras look down at an angle from above into the finish

3.3 Dual sidewall inspection with miho FSI

Function

Functions identical to the dual sidewall inspection, and in addition:

- detection and visual display (360°) of damaged and incorrectly manufactured threads for screw cap bottles
- detection of contamination and damage in the area of the side finish (for example, glass defects, glass cracks, rust rings, underchip damage, chipping)
- inspection regardless of the thread form:
  - segmented thread: twist off, vent slot
  - fault at the thread start / end
  - roughness of the thread is examined
  - contamination of the thread dial
- no false rejection of refunded new bottles anymore
- full inspection of the thread dial: from beginning to end, from below and from above

Technology

- as with the dual sidewall inspection
- an additional four cameras in the infeed module to ensure a full 360° view (transmitted light process)
- automatic adjustment of camera positions when changing bottle type



MCA: Damaged thread

MCA: Chipping at the flanged edge

MCA: Dirt in the threaded area

MCA: Rough thread

3.4 FSI-Upgrade flanged edge inspection

Function

As 3.3, additional detection of chipping at the flanged edge, for example with MCA threaded screw-top bottles. The following is detected:

- Chipping/bursts in the area of the flanged edge
- Friction rings below the flanged edge

3.5 Blowing device (glass bottles)

Function

For the removal of adherent water or foam residues in the area of the thread dial, in order to ensure a proper inspection

Technology

Blowing device before the empty bottle inspector, compressed air supply, optionally with sterile air filter, including control system and solenoid valve



Crown corks: Underchip defect

Crown corks: Vertical Split

4 miho David 2 | Integrated inspection of bracket area and clapper

The **three modules** for the comprehensive **swing top bottle inspection** in front of the filler in **one machine**.

- Dual sidewall inspection (DSW)
- Finish side inspection (FSI)
- Clapper inspection

4.1 Dual sidewall inspection with miho FSI for swing top bottles

Function

Detects amongst other things:

- Contamination
- Adhesive labels
- Missing bracket parts
- Missing clapper
- Vertical Splits
- Bracket assembly faulty



Swing top bottle with vertical split in the finish area



Swing top bottle with vertical split in the finish area



Bracket is missing

Bracket mounted the wrong way round

One-sided open bracket

4.2 Additional residual liquid detection

Function

Detection above the bottle base. To detect residual liquid in transparent bottles in front of the Empty Bottle Inspection Machine.

Examples of use for the inspection of swing top bottles:



4.3 Additional module clapper inspection

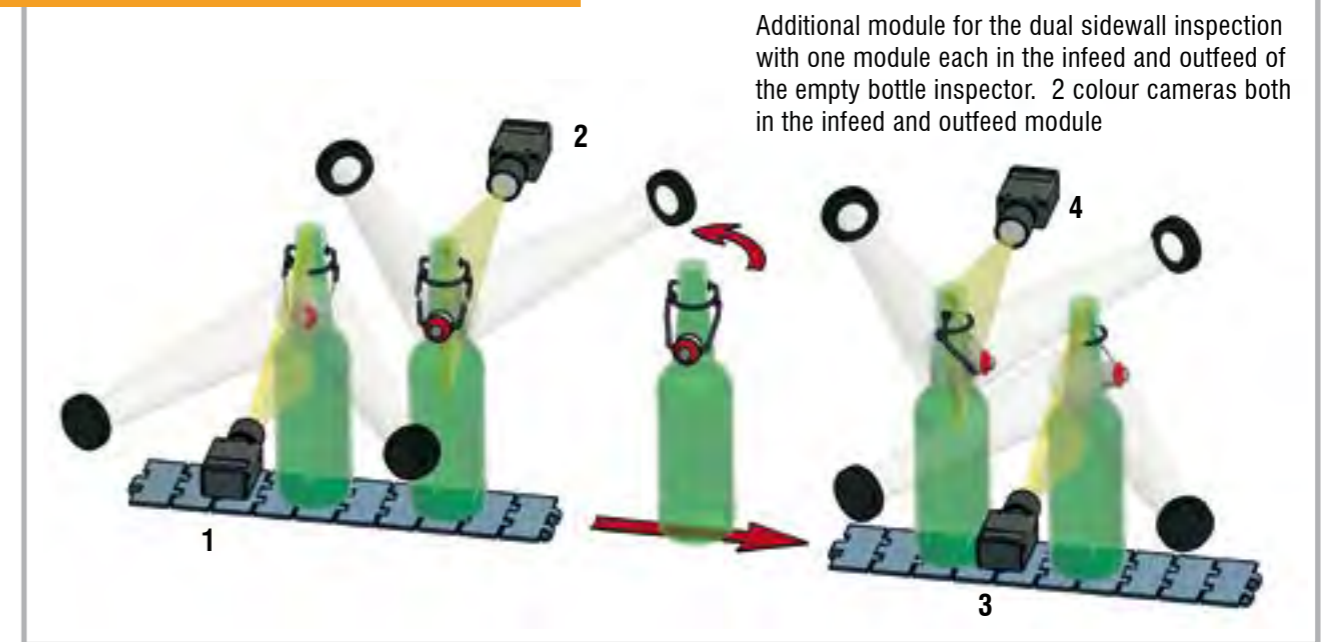

Additional module for the dual sidewall inspection with one module each in the infeed and outfeed of the empty bottle inspector. 2 colour cameras both in the infeed and outfeed module

Function

The following is inspected:

- Presence of the sealing rubber
- Colour of the rubber seal (colour and fading)
- Presence of the clapper
- Clapper: colour

Depending on the orientation of the clapper (the rubber seal must point to the camera):

- Dirt of the rubber seal, for example, mould
- Damage to the rubber seal, for example, missing material
- Damage to the pin, for example, bursts

The presence and colour of the rubber seal will be detected from every position of the clapper.



Clapper colour



Mould on the rubber seal



Rubber seal presence

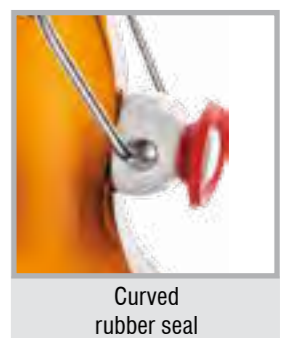

Curved rubber seal



Pins damaged



Rubber seal: colour and fading



4 miho David 2 | Integrated inspection of the bracket area

4.3 Bottling plant swing top bottles

Installed by miho:

- Complete bottle transportation
- Intelligent conveyor control
- All control and inspection systems:

After the washing machine:

- 1 Infeed control **miho Unicon 4** with rejection and additional residual liquid detector
- 2 Empty bottle inspector **miho David 2**

After the filler:

- 3 Fill Level inspection **miho Newton HF**
- 4 Ultrasonic bar for detecting leakage **miho UIP**

After the labeller:

- 5 360° inspection of a fully equipped bottle **miho Allround** with rejection

After the packer:

- 6 Full crate inspection **miho Gauss F**

Conveyor control:

- 7 Intelligent conveyor control system **miho Pascal 2** / central control cabinets

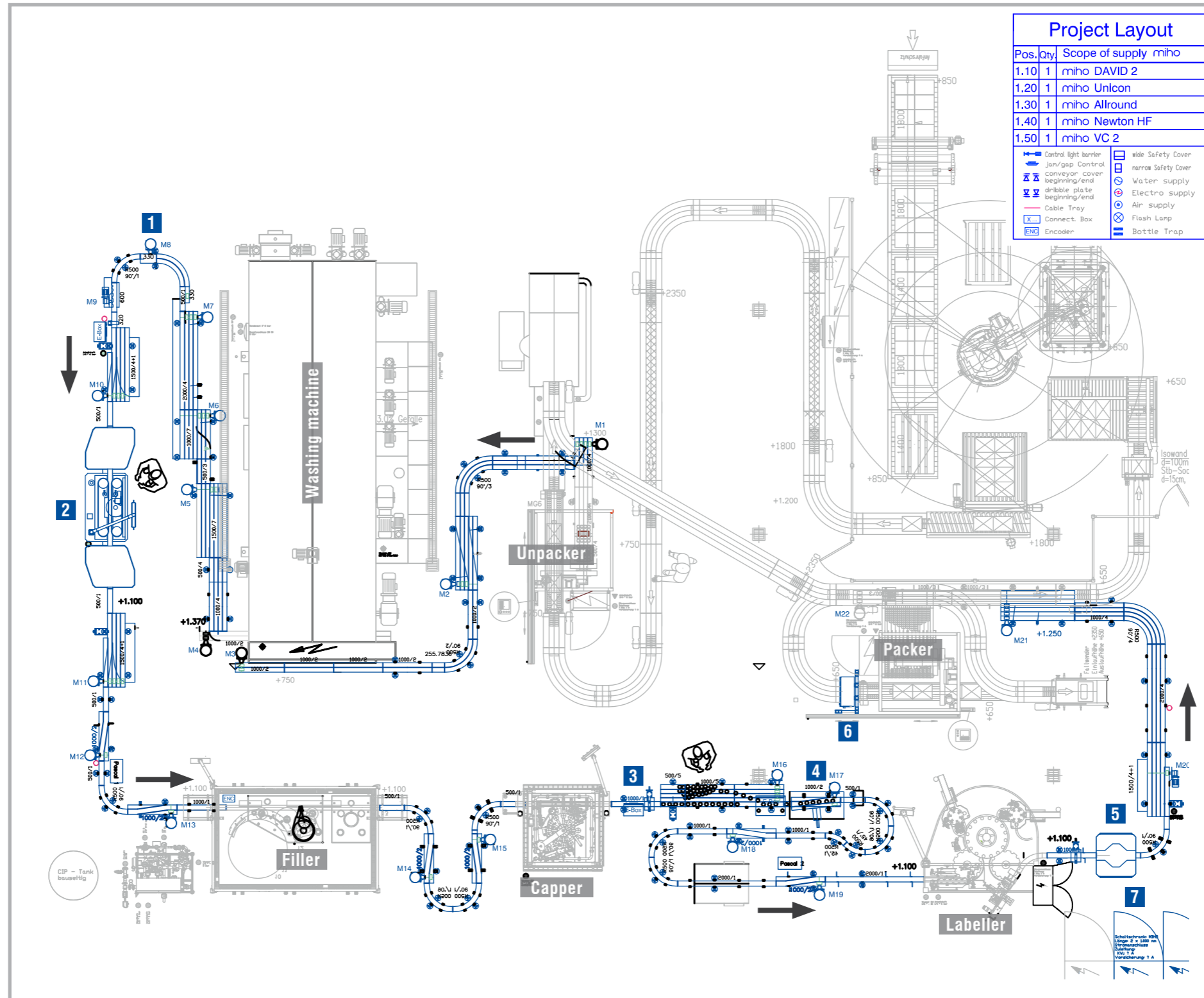

Incorrectly mounted



Distorted rubber seal



Bottle leaking (sweating)

Examples of use for the inspection of swing top bottles:



Detection of typical faults in PET returnable bottles:

- Scuffing
- Stress cracks
- Damaged or dirty vent slots and segment threads
- Faulty support rings
- Deformed bottle bases
- Correlation of the stress crack pattern and the likely later leakage of the bottle



Scuffing



Abrasion through faulty neck ring guide



Stress cracks



Burst at the support ring



Damage in the threaded area



Damage to the thread



Cracks in the finish area



Burst at the sealing surface / thread

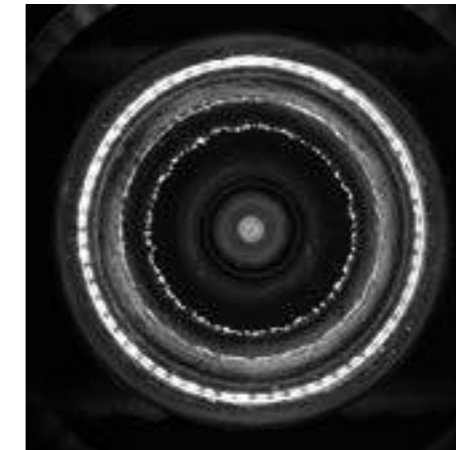

PET bottle: stress cracks, resulting in leakage

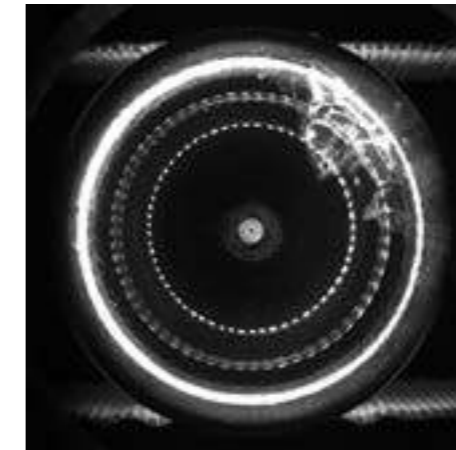

PET bottle: cigarette foil

5.1 miho Bottle Dryer

Function

Fast and thorough drying of the throat or neck ring especially for PET bottles to guarantee a flawless inspection of these areas. The containers will be guided with two driven special belts, running synchronized with the conveyor speed. Adjustable nozzles and controlled airflow achieve an optimized drying result. The belt system can be easily adjusted for different bottle diameters by using a handwheel. The regulated 4kW high performance ventilator with HEPA filter system generates the needed airflow.

Technology

- Stainless steel housing
- Drive control unit
- Robust, long life time and easy cleaning substructure
- Guide belts with reduced abrasion and quick fastening
- High performance blower and HEPA-filter (class 7)

For blowing off PET bottles: miho Bottle Dryer



5 miho David 2 | Integrated inspection of PET returnable bottles

5.2 Bottling plant returnable PET bottles

Installed by miho:

- Extremely accurate finish and thread inspection **miho FSI**, for example, to detect stress cracks
  - Extremely effective thread blowing to avoid false rejects
  - Secure standing rejection at 40,000 bottles / hour
- 1 High-performance thread blowing **miho Bottle Dryer**
  - 2 Infeed protection with foreign bottle inspection and sorting of scuffed bottles **miho Multicon 4**
  - 3 Empty bottle inspector **miho David 2** with:
    - dual sidewall inspection
    - finish side inspection **miho FSI**
    - sealing surface inspection with RGB-Lighting
    - base inspection with stress crack detection
  - 4 Linear segment rejector **miho Leonardo M** for standing rejection of empty and (partially) filled PET bottles
  - 5 Reject table, optimized for PET bottles
  - 6 Intelligent conveyor control system **miho Pascal 2** / central control cabinets

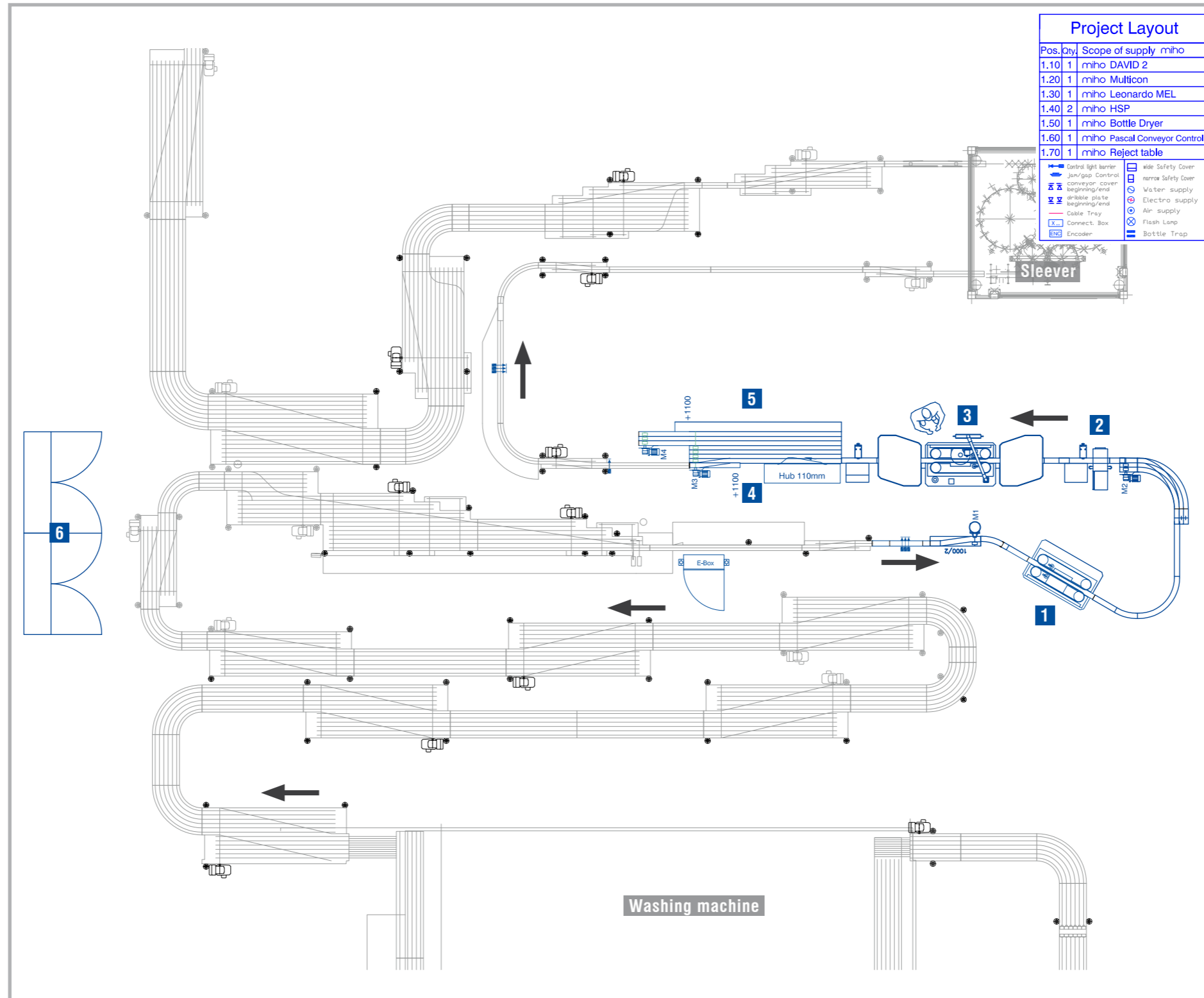

Dirty vent slot



Stress cracks



Permanent marker

Examples of use for the inspection of PET returnable bottles:



6 Examples of bottling plants

6.1 High-speed bottling line 72 000 bottles / hour

Installed by miho:

- Up to 72,000 bottles / hour; 5 different bottle types
- Integration into the existing conveyor control
- Connection to the existing PDAS of the customer

1 Infeed protection with foreign bottle inspection  
*miho Multicon 4*

2 Empty bottle inspector  
*miho David 2* with:

- dual sidewall inspection
- finish side inspection  
*miho FSI*
- sealing surface inspection with RGB-Lighting
- base inspection with Variofocus

3 High performance eccentric reject system  
*miho ESF 2*

4 Reject table, optimized for high speeds

A Good bottle, continues to the filler

B Dirty bottle, goes back to the washing machine

C Damaged bottle, goes to the container for broken glass

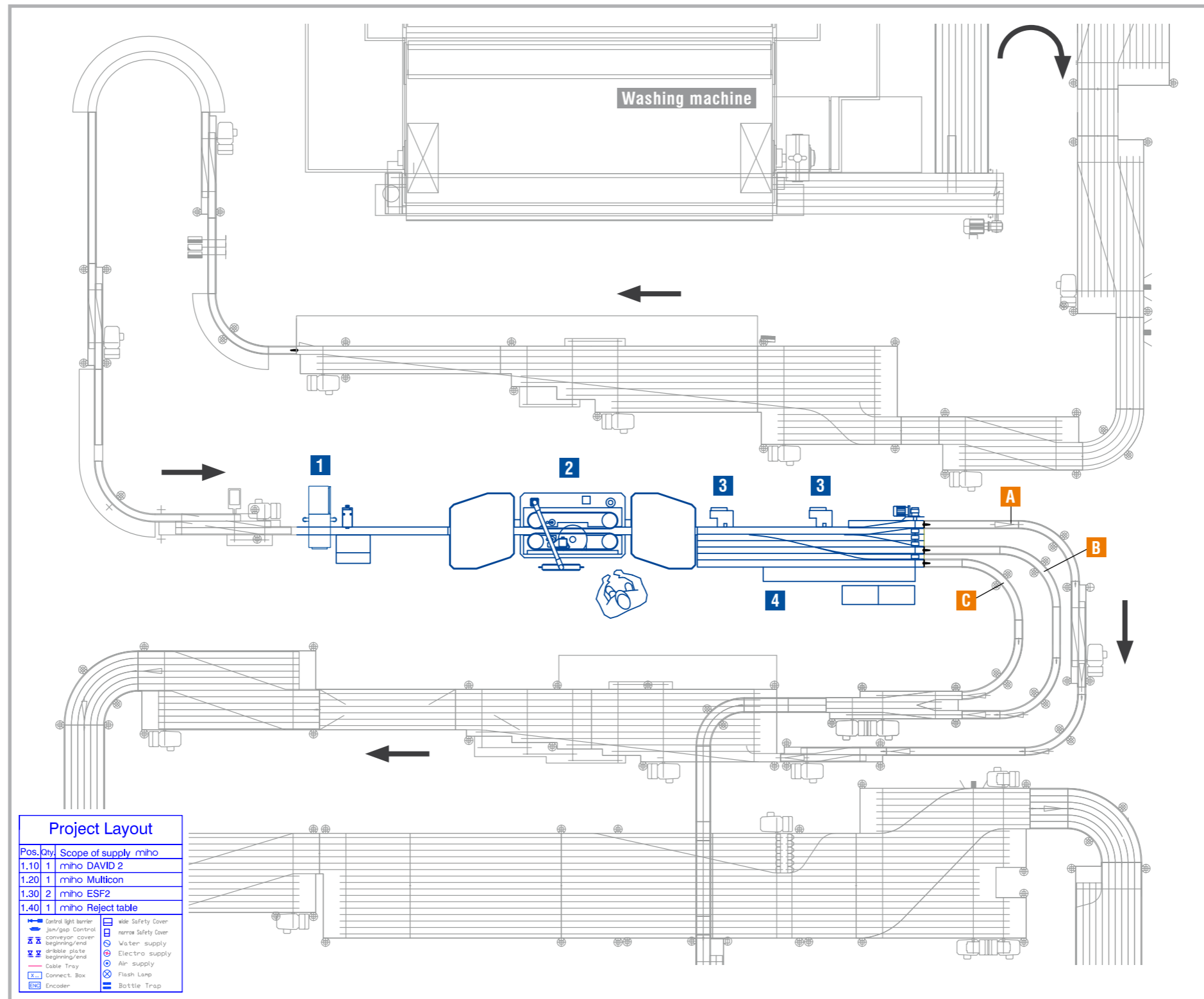

Damage in thread



Vertical split



Crown cork rust ring



6 Examples of bottling plants

6.2 Modernization of a bottling plant in confined spaces

Installed by miho:

- Cost-effective modernization: replacement of conveyor belts only where absolutely necessary
- Approximately 10,000 bottles/hour filling capacity in this example
- 1 Intelligent conveyor control **miho Pascal 2**, incl. buffer control
- 2 Conveyor construction **miho Conveyance**: The optimal solution of functional requirements in a given space
- 3 Infeed worm for creating a defined bottle division, ideal for swing top bottles
- 4 Camera based infeed control **miho Multicon 4**
- 5 Reject table for infeed control set at 90°
- 6 Empty bottle inspector **miho David 2** with:
  - dual sidewall inspection
  - finish side inspection **miho FSI**
  - sealing surface inspection with RGB-Lighting
  - base inspection with Variofocus
- 7 **miho HSPM** two-way rejection
- 8 Removal of the bottles rejected at the optimum location for the operator

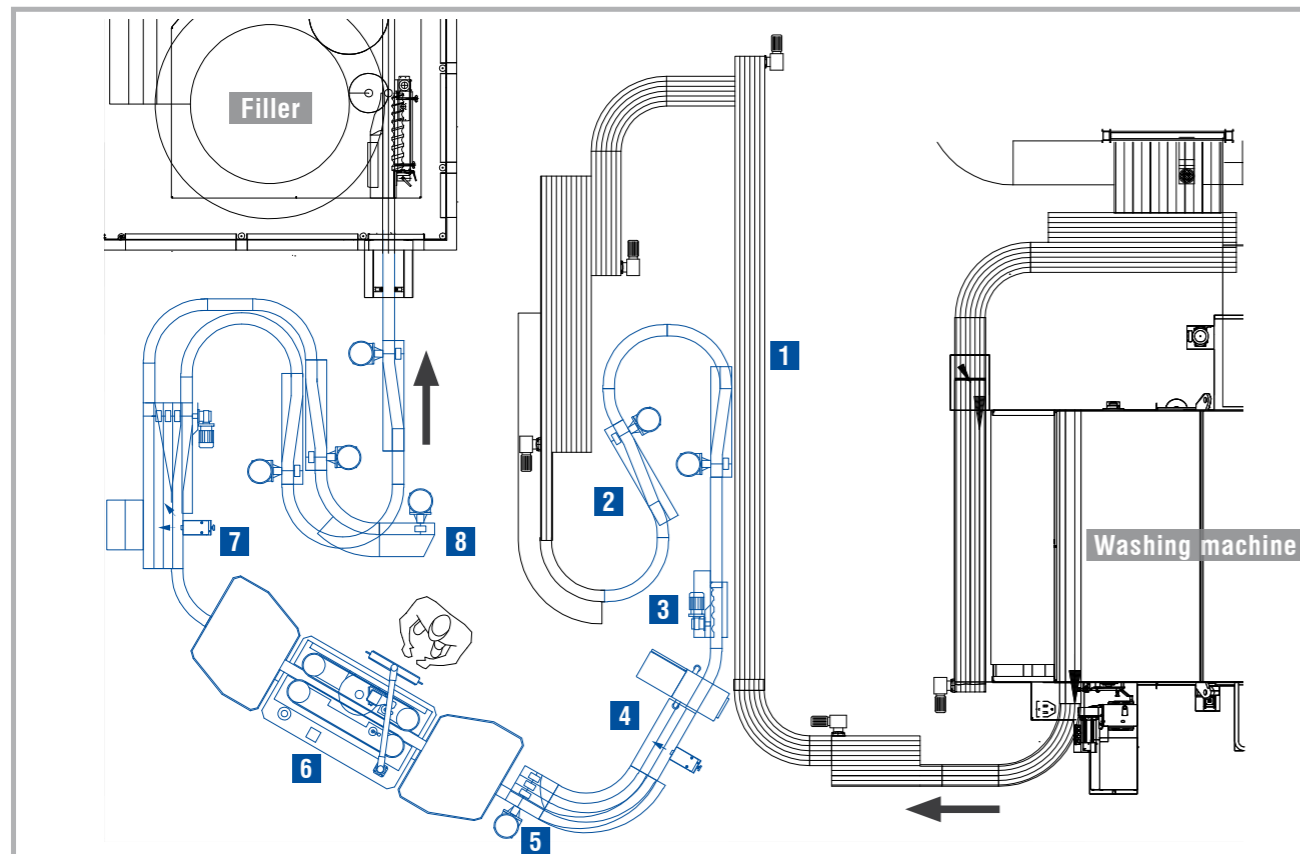

miho David 2 | Network integration & Production data acquisition

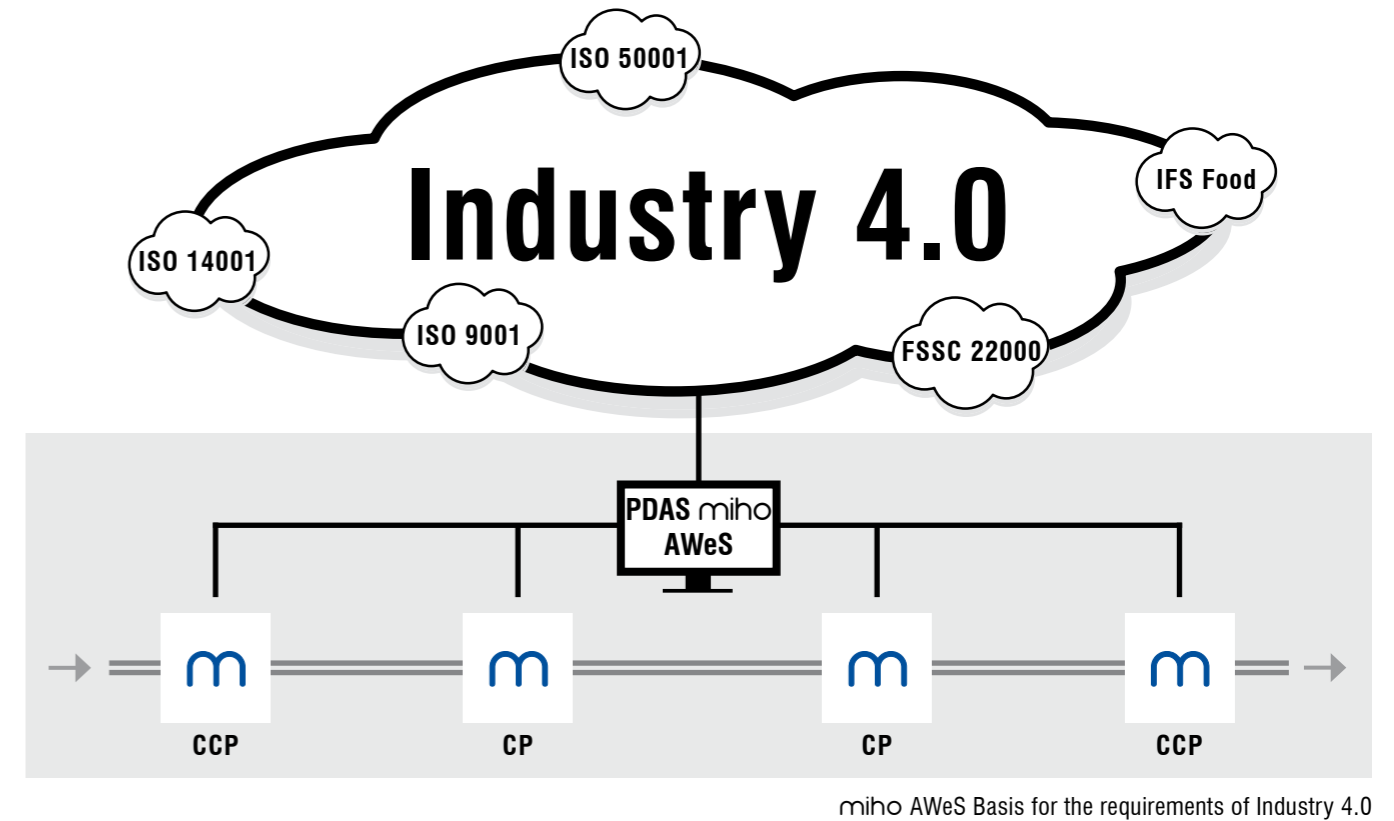

Why **network integration** ?

- **The empty bottle inspector is a prerequisite to**
  - monitor critical control points (CCP) in the filling process
  - initiate quality assurance countermeasures, if necessary
  - verifiably log all production conditions
  - comply with the duty of care of producers in accordance with HACCP, IFS or other country-specific requirements for risk management
- **Monitoring the filling process to control and improve efficiency,** for example, in the control room, integration of the empty bottle inspector in a company-wide production data acquisition system (PDAS)
- **Statistical evidence of minimum rejection,** in accordance with the specifications of the operator of the bottle pool
- **Remote diagnostics by miho** for carrying out maintenance and optimization measures - quickly and inexpensively
- **Basis for the requirements of Industry 4.0** and for modern certification standards: IFS Food, ISO 50001, FSSC 22000, ISO 9001, ISO 14001

7 miho David 2 | Network integration & Production data acquisition

7.1 Production data acquisition system miho AWeS

Part of the scope of delivery for the basic machine Advanced

Function

- Visualization and logging of:
  - counters
  - operating status
  - warning and error messages
  - test bottle runs
  - measures to correct faults after an unsuccessful test bottle run
  - user registrations
- to monitor single or multiple miho machines, such as the empty bottle inspector miho David 2, the inspection of a fully equipped bottle by the miho Allround, the fill level inspection miho Newton Optics 2, ...
- export of data in pdf or xls format for further processing
- **Backing up data in case of network failure - no data is lost.**

Technology

- polling the production data in accordance with the **Weihenstephan standard**, allowing easy integration into a PDAS
- either installation into the network on a virtual machine or on a separate PDAS computer from miho

Production Data	Inspection classes	String (1)	String (2)	Machine Data	Logging
By inspection unit				By inspection unit	
Base (1)	126	10.23 % *		Base	
Base (2)				Finish	
Finish (1)	1032	0.57 % *		Side wall	
Finish (2)				Thread	
Finish (3)				Finish side wall	
Side wall in (1)	154	10.05 % *		By fault	
Side wall in (2)	168	10.09 % *		Wrong bottle type	23 (0.02 % *)
Side wall out (1)	232	0.12 % *		Bottle top high	
Side wall out (2)	246	0.14 % *		Bottle too low	
Thread (1)				Wrong capped bottle	
Thread (2)				Defective sealing	228 (1.24 % *)
RFY-coupling				Defective bottom	306 (0.16 % *)
String	28	0.02 % *		Stuffing	
High frequency (HF)	8	0.05 % *		Closed bottle	
Infrared (IR)	6	0.05 % *		Foreign object	
Droplet base				Side wall fault	48 (0.27 % *)
Inner side wall				Residual liquid in the bottle	10 (0.01 % *)
Inner side wall (1)	288	0.16 % *		Undercap fault	5 (0.00 % *)
Inner side wall (2)	414	0.23 % *		Other faults	73 (0.04 % *)
Inner side wall (3)	211	0.17 % *		Broken bottle	2 (0.00 % *)
Inner side wall (4)	306	0.17 % *		Long bottle	0 (0.00 % *)
String (HF)					
String (IR)					

Screenshot miho AWeS user interface: Statistical analysis of the inspection modules and causes of rejection

Date	Time	Message	Value
2017-09-11	07:06	Successful testbottle run (all count reading ...)	48014
2017-09-11	08:19	Request for testbottle activated (all count reading ...)	50181
2017-09-11	08:22	Successful testbottle run (all count reading ...)	48014
2017-09-11	08:56	Request for testbottle activated (all count reading ...)	51013
2017-09-11	08:58	Successful testbottle run (all count reading ...)	48014
2017-09-11	09:00	Request for testbottle activated (all count reading ...)	49028
2017-09-11	09:15	Successful testbottle run (all count reading ...)	48014
2017-09-11	10:58	Request for testbottle activated (all count reading ...)	57162
2017-09-11	11:08	Successful testbottle run (all count reading ...)	48014
2017-09-11	11:23	Request for testbottle activated (all count reading ...)	527022
2017-09-11	11:29	Successful testbottle run (all count reading ...)	518707
2017-09-11	14:20	Request for testbottle activated (all count reading ...)	54214
2017-09-11	14:28	Successful testbottle run (all count reading ...)	52023
2017-09-11	14:58	Request for testbottle activated (all count reading ...)	44058
2017-09-11	15:00	Successful testbottle run (all count reading ...)	48290
2017-09-11	17:42	Request for testbottle activated (all count reading ...)	74632
2017-09-11	17:53	Successful testbottle run (all count reading ...)	76028
2017-09-11	18:52	Request for testbottle activated (all count reading ...)	524000
2017-09-11	20:06	Not successful testbottle run (all count reading ...)	528071
2017-09-11	20:06	Request for testbottle activated (repeated read ...)	528000
2017-09-11	20:07	Successful testbottle run (all count reading ...)	528027
2017-09-11	21:40	Request for testbottle activated (all count reading ...)	5428
2017-09-11	21:41	Successful testbottle run (all count reading ...)	52013
2017-09-11	21:52	Request for testbottle activated (all count reading ...)	5067
2017-09-11	22:13	Successful testbottle run (all count reading ...)	40728

Screenshot miho AWeS user interface: Example of a successful test bottle run

miho AWeS as the central PDAS

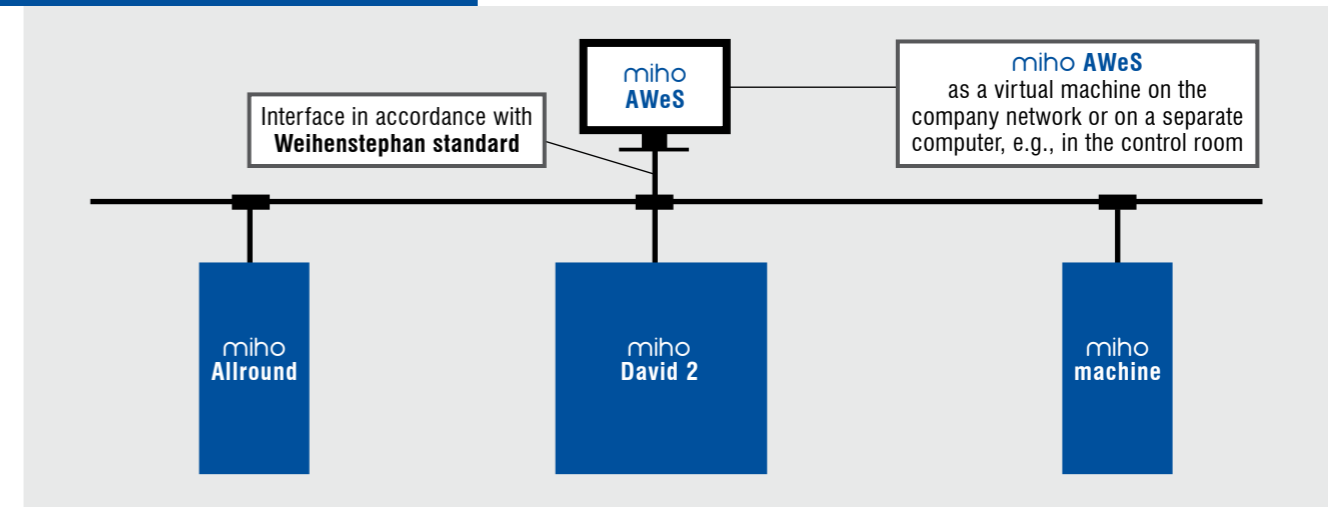

Integration of miho machines into an existing PDAS

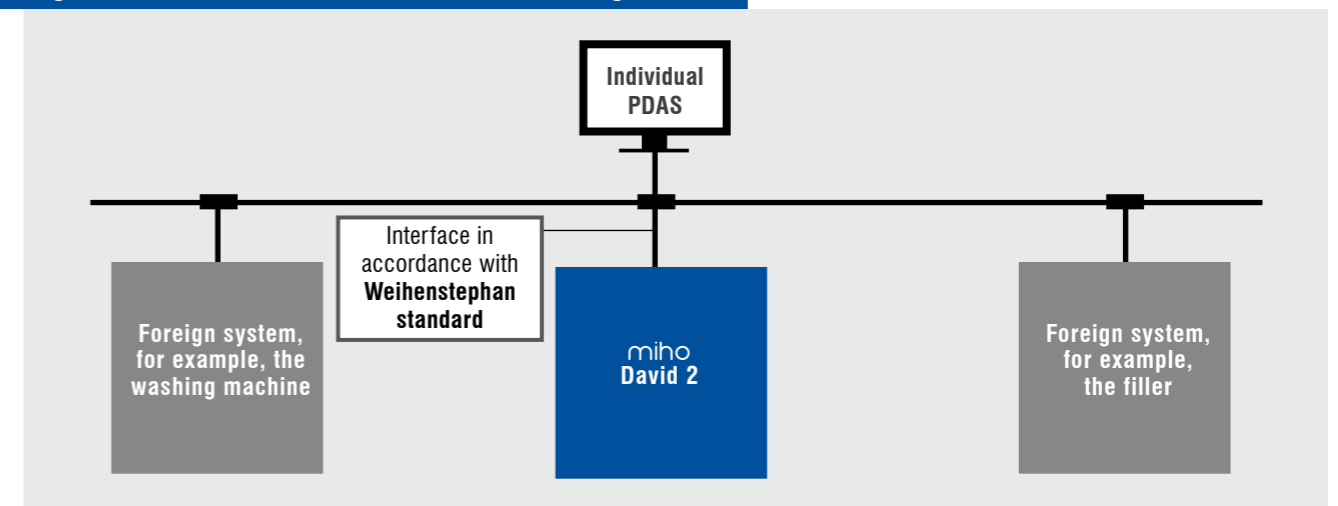

7.2 miho remote maintenance

Part of the scope of delivery for the basic machine Advanced / basic machine Eco

Function

Software package for remote visualization of the operating status, the parameters and images on an authorized computer of a miho service engineer: monitoring of counters and disruptions, checking and operating the inspection systems, new input and optimization of inspection parameters, accurate and quick analysis of faults.

Technology

- Internet access with data transfer of at least DSL standard
- **OpenVPN**, a globally recognized tool for establishing a virtual private network via an encrypted TLS connection, or alternatively with TeamViewer (licence supplied by the customer)



8 miho David 2 | Upgrade modules

8.1 Inner sidewall inspection

**Function**  
To detect three-dimensional dirt on the inner side wall, which is, for example, obscured by ACL labels or glass embossing. Restriction of the viewing angle is dependent on the bottle shape.

**Technology**  
Lighting by a maintenance-free LED lighting unit from below, camera-based detection above the bottle.

8.2 Standard thread inspection

**Function**  
To detect damaged thread dials in screw cap bottles (MCA), with camera technology and maintenance-free LED lighting unit.

**Technology**  
Lighting unit and camera above the bottle finish, special mirror arrangement for inspecting from the side (incident light or reflection method).

8.3 Extension of visual angle of the base inspection

**Function**  
Extension of visual angle of the base inspection for improved inspection of longneck and / or swing top bottles.

8.4 Additional UV filter detection

**Function**  
To detect clear glass bottles with or without UV filtering for subsequent sorting.

**Technology**  
Absorption measurement with a UVA detector, sensitive to a wavelength of 365 nm, including hardware and software kit.

8.5 Automatic adjustment when changing the bottle type

**Function**  
Automatic adjustment of inspection head height and the belt width when the operator changes the bottle type on the touch screen of the inspector.

**Technology**  
Adjustment via servomotors, all parameters of that setting are stored under miho VIDIOS® according to type.

8.6 Undervoltage supply

**Function**  
Equipment of the empty bottle inspector with integrated uninterruptible power supply (UPS) for controlled shutdown in case of mains interruption or a power failure.

**Technology**

- The fuse is integrated in the electronic housing of the basic machine
- Uninterruptible power supply with IQ Technology 1AC / 1AC / 500 VA



A miho development engineer at the evaluation of a prototype board test by a miho technician



Circuit board test by a miho technician

8 miho David 2 | Upgrade modules

8.7 Drip trays

Function

Drip trays for the empty bottle inspector miho David 2 for systems with particularly high consumption of belt lubricant.  
Drip trays in the infeed and outfeed area of the empty bottle inspector.

Technology

- Drip trays made out of stainless steel
- Easy to disassemble and clean
- Central drain in the infeed and outfeed areas
- Easy to upgrade

8.8 Separate computer for PDAS miho AWeS

Function

Separate PC system incl. monitor and printer for operation with the production data acquisition software miho AWeS. Also enables the integration of additional miho machines. Also available as an option to set up the remote maintenance connection.

Technology

Min. Intel Core i5, min. 4 GB RAM, min. 250GB SSD, min. 2x PCIe slot, min. 2x Ethernet (RJ45), min. 1x VGA or DVI / HDMI, screen resolution min. 1400x1050 pixels, operating system Microsoft Windows 10 Professional (min. Version 1803, 64bit), German or English.

8.9 Separate AWeS viewer

Function

Remote visualization of the operating status of the empty bottle inspector on a separate computer, for example, in the foreman's office

Technology

Installation of a separate viewer, for example, on a separate miho AWeS computer from miho; network connection is necessary. Requirements in accordance with miho IT-regulations

8.10 Safety cabinet

Function

- improved access safety guard to the bottle conveyor belts
- operator protection against broken glass
- enhanced protection of bottles within the inspector from contamination by adjacent units or bottle conveyors
- improved soundproofing

Technology

- 2 large-size safety doors on the front side
- monitoring through non-contact, tamper-resistant security switches, integrated into the ASI bus safety system of the machine



Mechanical installation of the miho David 2 basic machine



Empty bottle inspector miho David 2 with safety cover

General features of the infeed control:

- **Machine protection for**
  - too high, too low or lying bottles;
  - broken shards of glass
- **Bottle sorting**
  - shape, colour, height
  - secondary characteristics such as embossing, ACL labels

9.1 Infeed control miho Unicon 4

Function

- infeed control before the empty bottle inspector for broken bottles, lying bottles and bottle height

Technology

- light barrier technology
- control and reject monitoring by the empty bottle inspector



Infeed control miho Unicon 4

9.2 Infeed control miho Multicon 4

Function

- camera-based infeed control (lying bottles, broken bottles) before the empty bottle inspector
- sorting in accordance with shape, colour and differences in size
- compensation of disruptive factors such as labels sticking out, drinking straws etc...
- independent of the container material, even PET
- sorting of bottles based on secondary features such as embossing, permanent labels or degree of scuffing

Technology

- image processing system miho VIDIOS® and modern colour camera system, innovative lighting concept
- rejection in accordance with different sorting criteria to different reject channels is possible
- glass-PET distinction is a possible option
- control and reject monitoring by the empty bottle inspector



Infeed control miho Multicon 4

10 Reject systems

miho rejection - four systems for different requirements:

- the appropriate reject system, depending on the function and requirement
- all reject systems including reject monitoring
- central control system through the empty bottle inspector

10.1 Reject system miho HSP

Function

- to reject the faulty bottle via a pneumatic pusher
- including reject monitoring in the empty bottle inspector

10.2 Multi-reject system miho HSPM

Function

- Universal use in glass and plastic bottles, as well as in cans or carton packaging, empty or filled
- up to 60,000 containers per hour
- different container shapes and weights are compensated thanks to the servo-control of the linear drive and have no influence on the motion sequence of the reject block
- the reject process is individually configured for different container types and optimized for the respective container type

Technology

- the reject block of the miho HSPM is driven by an optimized high speed linear servomotor
- parameterization and operation integrated in upstream inspection unit
- low maintenance and durable
- no compressed air supply necessary
- including reject monitoring in the empty bottle inspector

10.3 Eccentric reject system miho ESF 2

Function

- for the rejection of cans, glass or plastic bottles with a specially shaped and rotating reject block
- for high conveyor speeds

Technology

- driving the reject block with a servomotor, independent of load and long-term stability
- high standing stability of the bottle by slight vertical downward pressure whilst rejecting
- horizontal and vertical adjustment of the reject block with rail guide
- including reject monitoring in the empty bottle inspector



miho HSPM: multiple rejection (red arrows), depending on the type of bottle defect

10.4 Segment reject system miho Leonardo M

Function

- secure standing rejection of bottles, cans and carton packaging, even of difficult bottles in terms of shape and centre of gravity
- suitable for sorting tasks

Technology

- magneto-mechanical reject system: containers to be rejected are transferred to a parallel conveyor by slide segments which run synchronously and parallel to the conveyor
- gearless drive via toothed belt, thus less mass movement and low-wear
- torque monitoring of the servomotor through slip clutch
- including reject monitoring in the empty bottle inspector



miho Leonardo M, slide segments in action

Reject principle:

The mechanical core piece of the **Leonardo M** is the approximately **100 reject slides (1)**, each one being connected to its own private **guide element (2)**. They are all permanently driven parallel to the reject conveyor and synchronously with the belt speed. If a bottle is to be rejected, the **central switching unit (3)** electromagnetically moves two or three of the guide elements in a mathematically calculated **curve (red line)** vertically to the running direction of the conveyor. Thus, by activating the reject slides in this way, the bottle to be rejected is pushed **gently and securely standing** onto the parallel reject conveyor (left reject conveyor, not pictured).

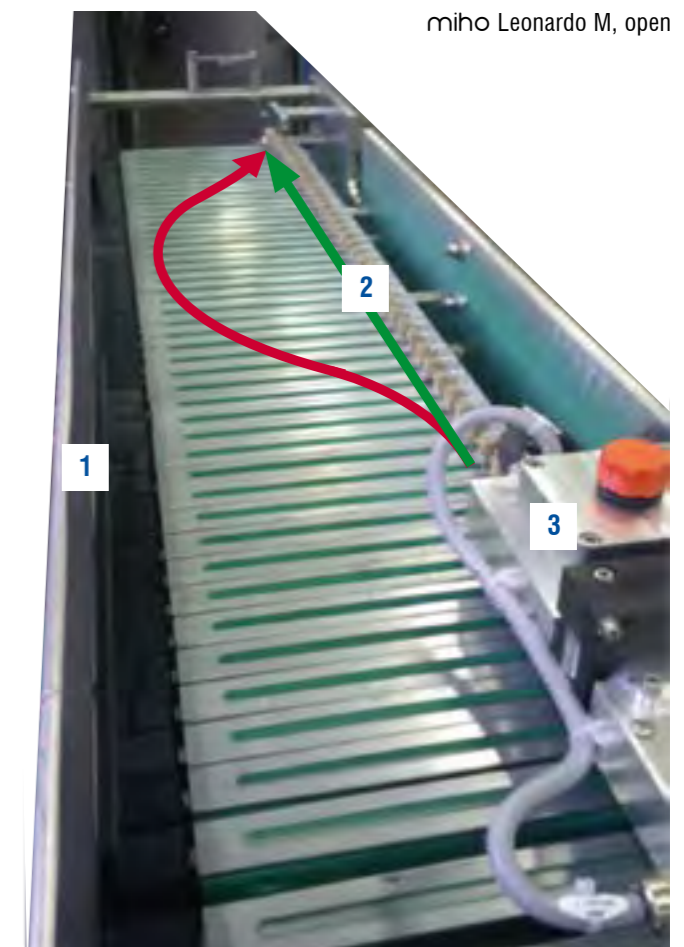

miho Leonardo M, open

11 Conveyor control | Conveyor construction | Container transport

From a single source:

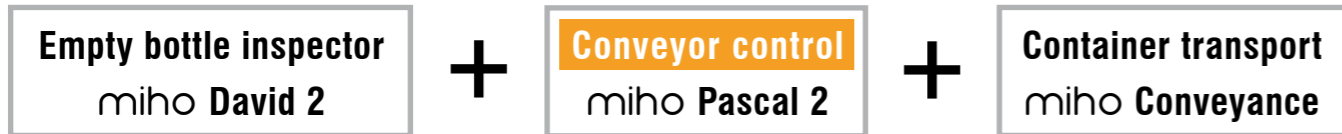

Conveyor control

- contactless compensation of bottle gaps: reducing the noise and bottle abrasion
- **one** single control unit from the washing machine to the filler
- a modern conveyor control system brings efficiency, less disruption, less idle running at the filler

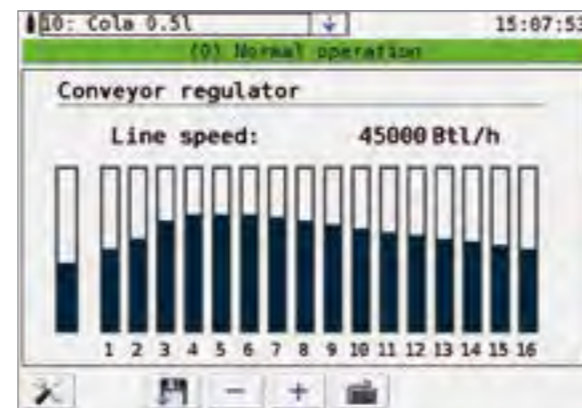

Display of different motor group speeds

11.1 Intelligent conveyor control system miho Pascal 2

Function

- early detection of one of the nominal output deviating transportation capacities of the bottle line
- gaps created by rejected containers are compensated for without any container contact
- smooth and low noise gap closure for smooth bottle transport
- buffer control, isolation and single-lane blocking between two aggregates with only one control module miho Pascal 2
- reduction of aggregate interference from a lack of bottles at the infeed
- remote-controllable change of bottle type, no user intervention is necessary
- the operator is informed of the status of the system with messages in the local language
- alarm detectors can also inform on plant status on the spot
- user administration with individual access authorization of the operators

Technology

- microcontroller technology for quick responsive conveyor control in real time
- millimetre-precise detection of gap size
- no counting method: removing or adding bottles has no influence
- Allocation of the system section into up to **16 motor groups** with different speed adjustments
- production data acquisition in accordance with Weihenstephan standard and remote visualization for example, in the foreman's office
- a **graphical user interface** with touchscreen makes operating for the user even easier
- Data backup of user-specific parameters on SD card
- no additional software necessary
- easy integration of the miho Pascal 2 into existing bottling plants.
- up to 18 gap sensors and up to 8 buffer sensors

11.2 Additional module conveyor control through the empty bottle inspector

Adjustment of the conveyor control system miho Pascal 2 and the selection of suitable sensors is carried out automatically when changing the bottle type on the empty bottle inspector miho David 2.

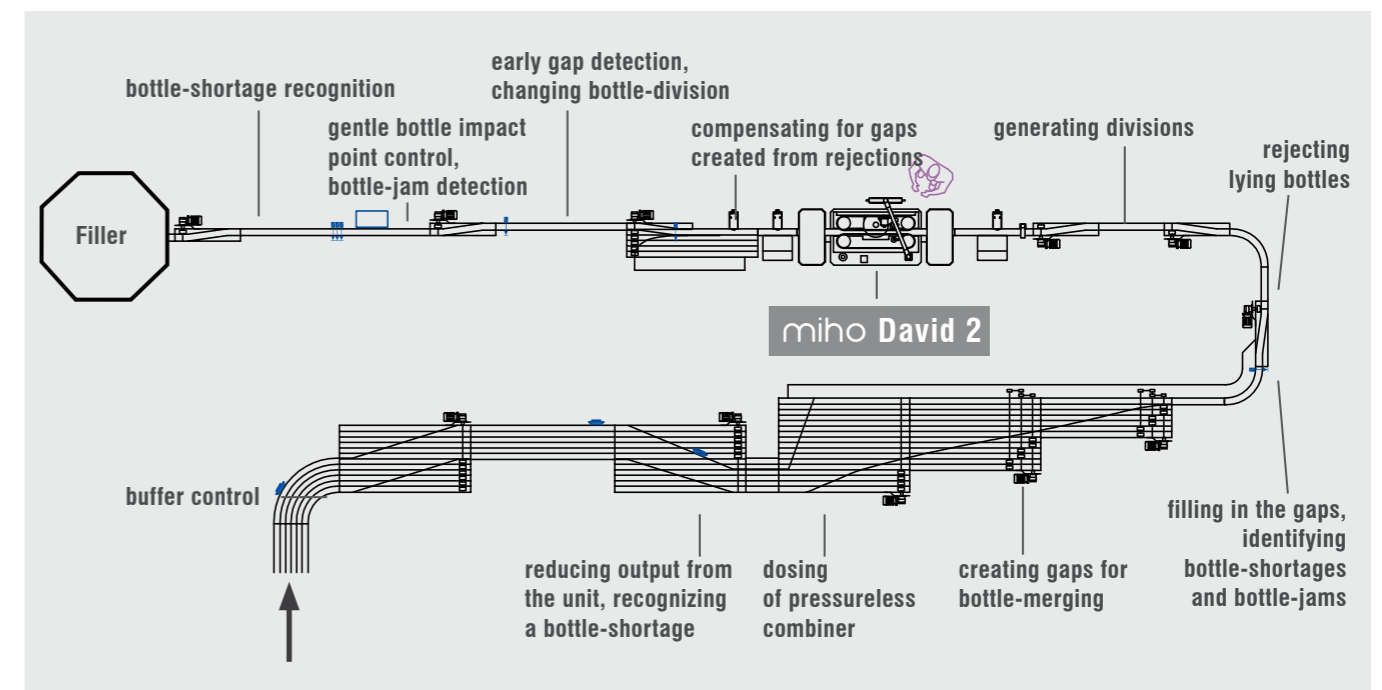
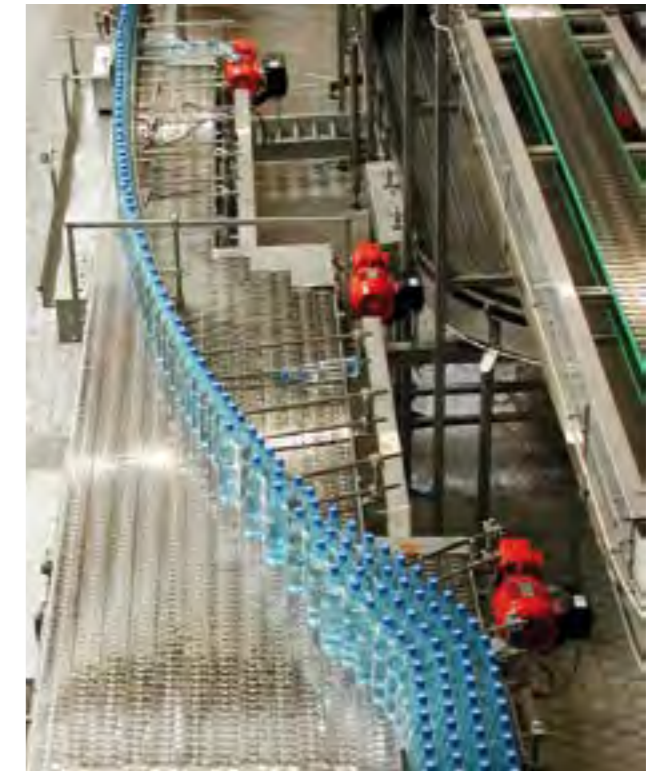

Concept for conveyor control miho Pascal, from the washing machine to the filler

11 miho Conveyance container transport

From a single source:

Empty bottle inspector  
miho David 2



Conveyor control  
miho Pascal 2



Container transport  
miho Conveyance

Conveyor construction

- Conveyor construction made out of stainless steel
- Depending on the project conveyor chains made out of stainless steel or plastic are possible (Rexnord)
- Curved conveyors with magnetic chain guides
- Chain sprockets are dividable
- Bottle railings are made out full profile stainless steel, with plastic bottle guides depending on the requirements of the project
- Railing holders made of stainless steel, adjustable where necessary
- Piping for conveyor lubrication made of stainless steel pipes, for the connection to the existing lubrication system
- Stainless steel wire-basket cable trays, open. Other variations upon request

11.3 Container transport system  
miho Conveyance

- modular container transport system for modern filling and sorting systems
- single and multi-lane conveyors, pressureless combiners, buffer systems and reject tables
- high quality reject tables from miho are a requirement for secure standing rejection
- hygiene-friendly design details
- pre-assembled in the factory, thus short installation and commissioning times
- miho Conveyance und miho Pascal 2 form a combined basis for smooth production and high plant efficiency



Reject table, with belt lubrication, height-adjustable foot receptacle and optional drip tray



Curve with optional drip tray and height-adjustable foot



Two-sided rail adjustment



Optional conveyor belt cover



Mechanical pre-assembly in the factory at miho



miho Conveyance, individual special solution for collecting lying bottles in hard to reach places

12 Recommended installation | Technical Data

12.1 miho David 2 with dual sidewall inspection and miho FSI as well as an additional reject table for the infeed control

Recommended installation

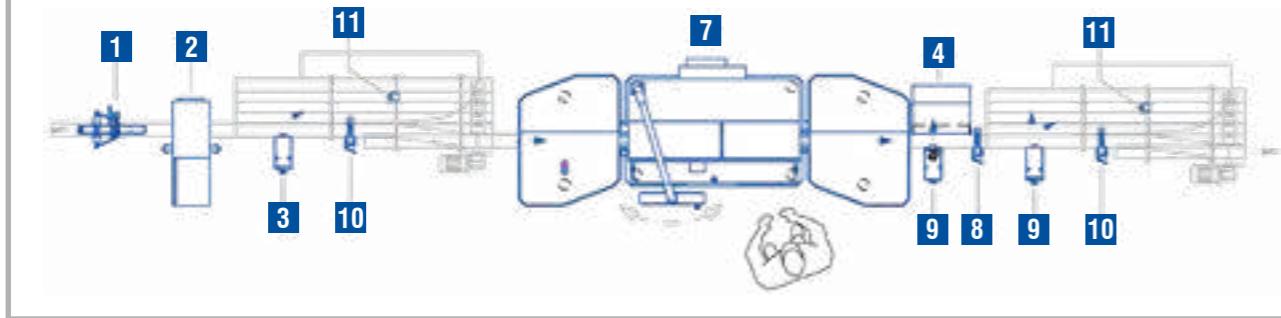

12.2 miho David 2 with dual sidewall inspection and miho FSI

Recommended installation

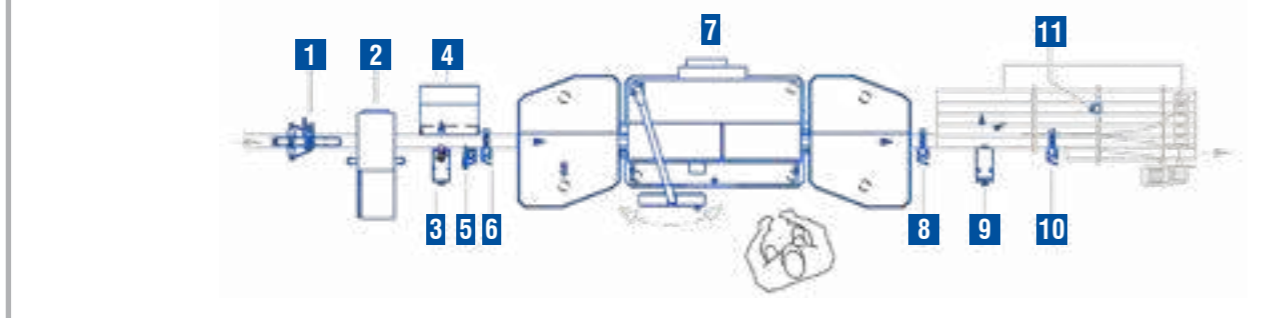

12.3 miho David 2 with standard sidewall inspection

Recommended installation

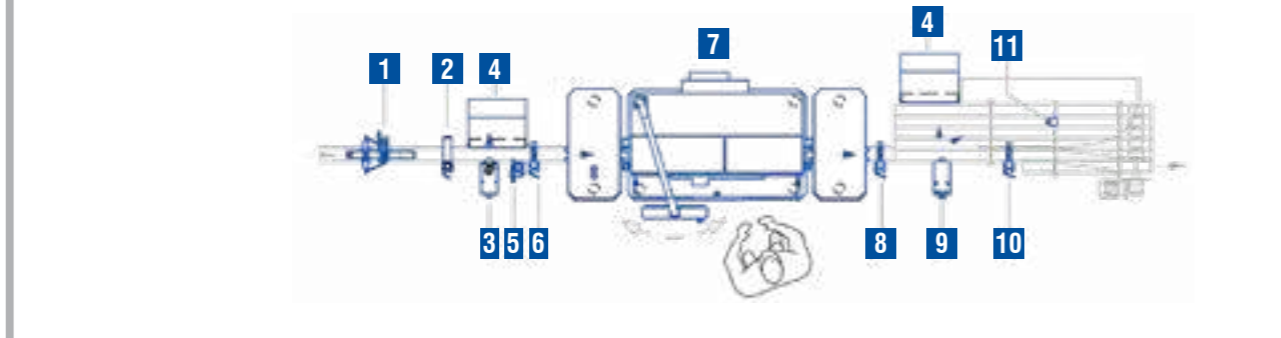

12.4 miho David 2 with basic functions, for example base and finish inspection

Recommended installation

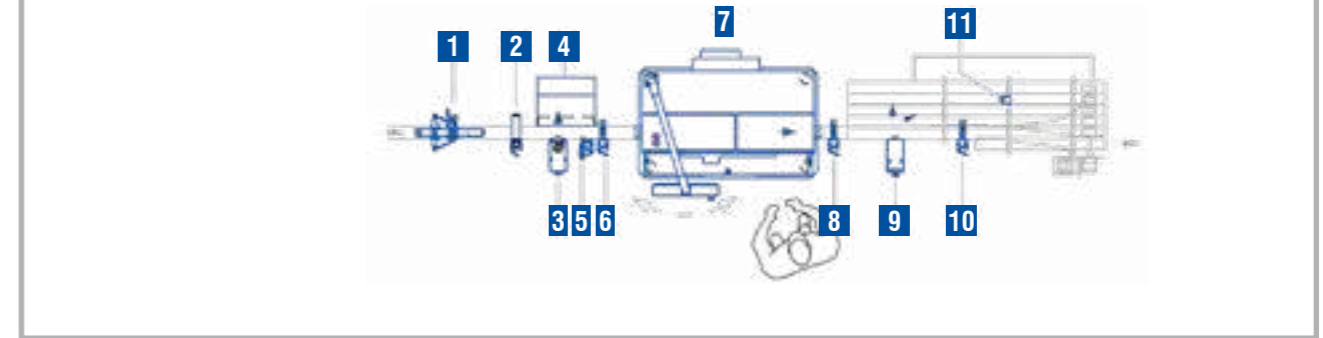

Legend

- 1 Optional finish blow-off system
- 2 Infeed control (e.g. Unicon 4 or Multicon 4)
- 3 Reject system after infeed control (HSP)
- 4 Glass shards cover
- 5 Reject system for laid down and broken bottles (blow-out)
- 6 Reject monitoring
- 7 Empty bottle inspector miho David 2
- 8 Trigger-Light barrier
- 9 Reject system after empty bottle inspector (HSP, HSPM, ESF 2, Leonardo M)
- 10 Reject control
- 11 Optional table monitoring

Operation

- temperature +10°C to +40°C
- relative humidity: 30% bis 90%

Cleaning

- cleaning plans in accordance with the instruction manual
- with standard industry cleaning agents

Supply

- operating voltage 230 V +/- 10%, 1-phase AC
- frequency: 50 Hz bis 60 Hz
- power < 1.5 kW
- pneumatic, operating pressure: 5 bar - 10 bar

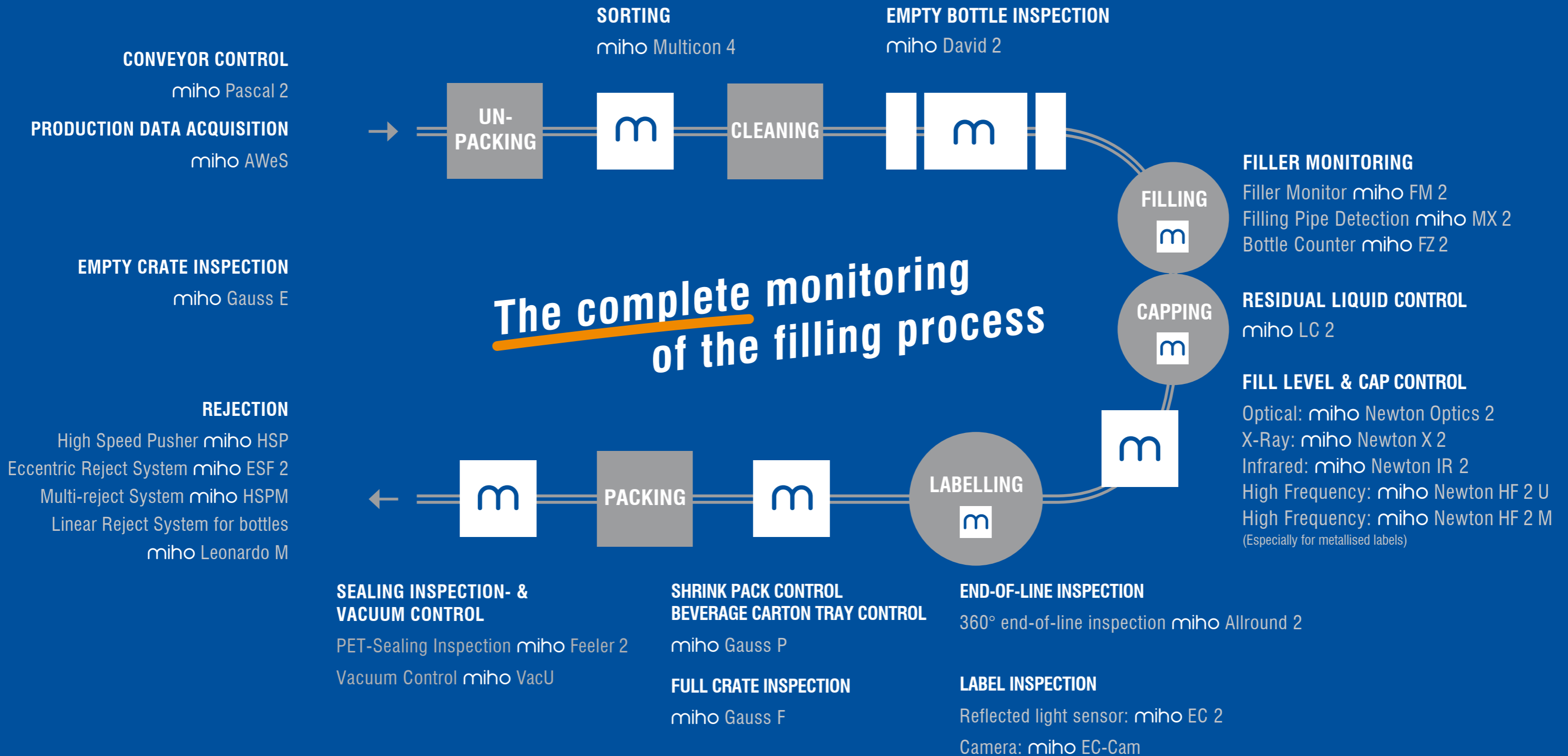



# The miho sales team

**Thomas Mathusek**  
Regional Director  
Asia / Pacific / Europe

+49 5609 8382-16  
tmathusek@miho.de

**Dr.-Ing. Markus Grumann**  
Managing Director

+49 5609 8382-35  
mgrumann@miho.de

**Luc Tricot**  
Regional Director  
Western Europe

+32 47 52 53 88 3  
ltricot@miho.de

**Peter Schirmer**  
Regional Director  
Africa / Middle East

+49 5609 8382-36  
pschirmer@miho.de

Follow the  
QR code to find  
your local  
miho partner:



**Oliver Kory**  
Regional Director  
Americas / China /  
Eastern EU

+49 5609 8382-47  
okory@miho.de

**Herbert Liebich**  
Key account manager  
Germany

+49 5609 8382-23  
hliebich@miho.de

**Philipp Wedel**  
Area sales manager  
Germany, Austria, Switzerland

+49 5609 8382-20  
pwedel@miho.de

miho Inspektionssysteme GmbH · Obervellmarsche Str. 12 · 34292 Ahnatal · Deutschland  
+49 5609 8382-0 · info@miho.de · www.miho.de

miho Inspection System Nigeria Ltd. · 35A Furo Ezimora Street · Marwa Bus Stop · Lekki Phase 1  
Lekki Expressway, Lagos · Nigeria · +234 0129 1693-0 · office.nigeria@miho.de · www.miho.de

Guangzhou miho Inspection Equipment Ltd. · Room 601 · Yingli Building · No.144 Pinkang Road  
Shiqiao Street · 511400 Panyu District, Guangzhou · China · +86 20 39936110 · info@mihochina.com · www.miho.de