

# MARKSMAN<sup>®</sup> 1600HSi

*"The World's Most Trusted High Speed Can Wrap Machine"*

**CAN PACKAGING SYSTEM**

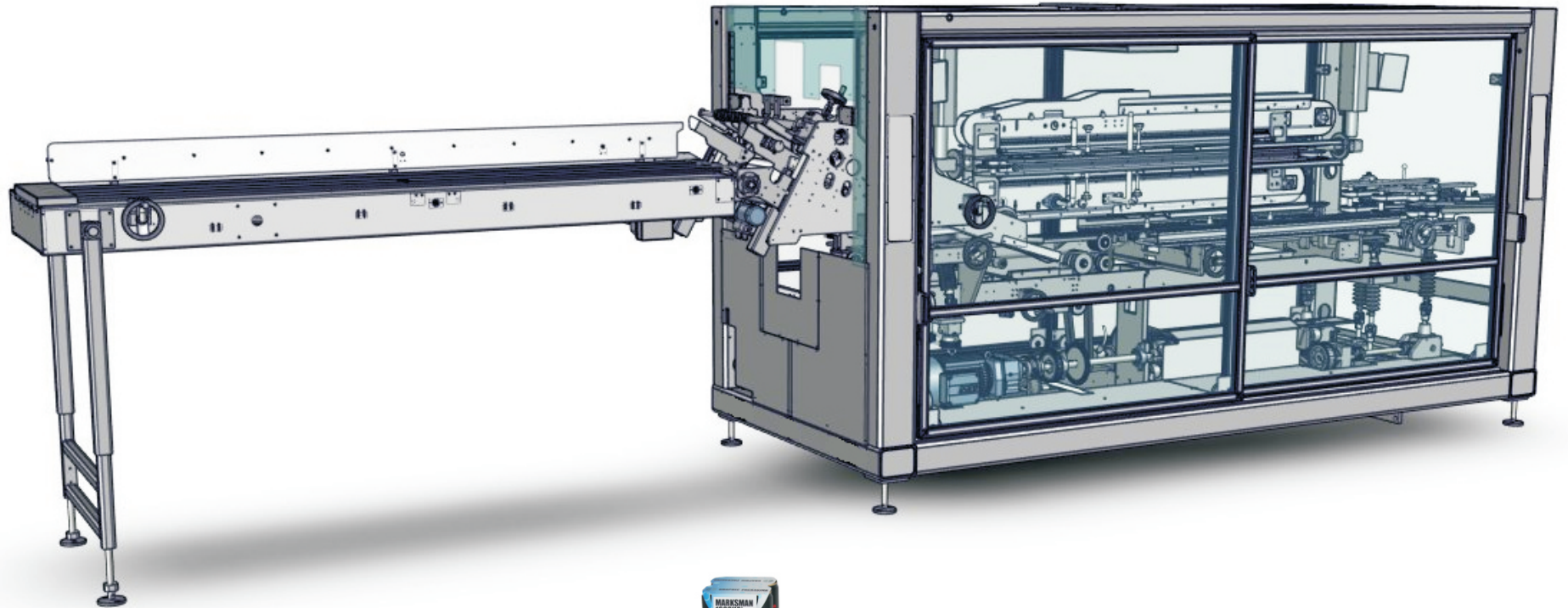

Graphic  
Packaging  
INTERNATIONAL, INC.

Continuing its legacy of being the most efficient high-speed can wrap machine available, the new Marksmen 1600HSi machine now runs multiple diameter cans and larger pack sizes, including 10-pack and 12-pack.

# Marksman® 1600HSi Specifications

## Machine Footprint

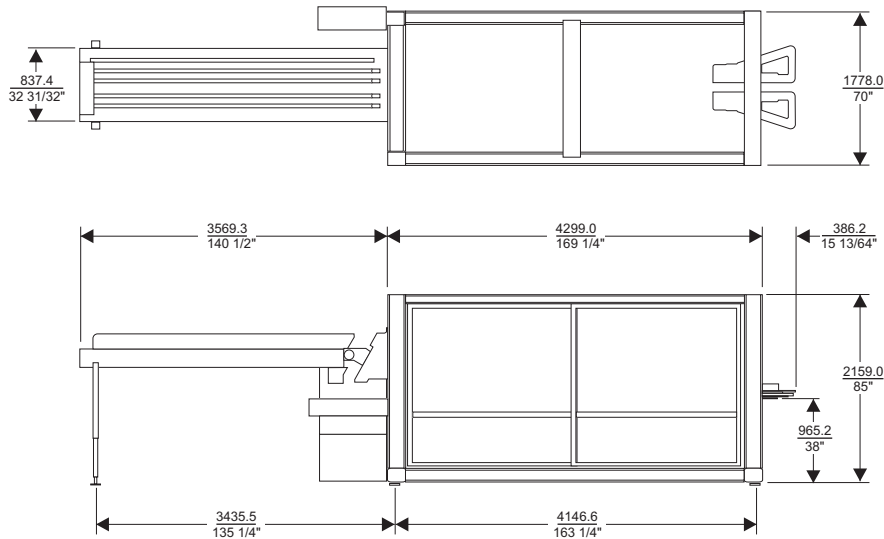

## Standard Package Styles

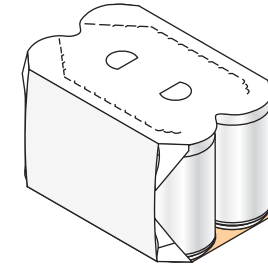

Top/Bottom  
Corner Gusset

## Optional Package Styles

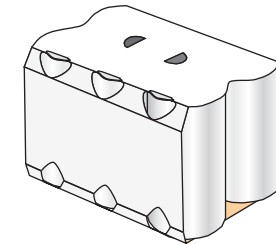

Straight  
Wrap

## Key Features

### Top and Bottom Gussets

Cans are securely wrapped in top and bottom gusseted packages that require less paperboard than other multipack paperboard packaging.

### High Speed Packaging

Unpitched product flow allow speeds up to 2,400 cans per minute.

### Complete Guarding

Walk-in sliding doors  
Complete interlock safety guarding

### Quick and Simple Changeover

Changeovers are optimized with our no-tool adjustment technology.

### PLC Control

Uses advanced software technology.

### Machine Dimensions

14"1" long, 5'10" wide, 7'1" high  
(4.30m x 1.78m x 2.16m)

### Machine Weight

Approximately 11,460 lbs. (5198kg)

### Speed Range

Operates at speeds up to

	Line	Surge
2x2	400ppm	450ppm
2x3	350ppm	400ppm
2x4	250ppm	300ppm
2x5	200ppm	240ppm
2x6	166ppm	200ppm
1x packs - Same ppm as 2x packs		

### Air Requirements

With Vacuum Pump:  
80 PSI - 3 CFM (6 Bar - 5 m3/H) Standard  
With Pneumatic Vacuum Option:  
80 PSI - 22 CFM (6 Bar - 16 m3/H)

### Electrical

400/460 VAC, 24 Kw  
3 Phase, 50/60 Hz

### Lubrication

No oil or grease needed

### Package Configurations

Standard 2x2, 2x3, 2x4  
Optional 2x5, 2x6

### Product Ranges

Standard - Fixed diameter, multiple heights  
Optional - Up to four different diameters\*

Min Diameter 53mm  
Max Diameter 66mm

Min Height 79mm  
Max Height 189mm



 **Graphic Packaging**  
INTERNATIONAL, INC.

Graphic Packaging International, Inc.  
1500 Riveredge Parkway  
Atlanta, GA 30328  
Phone (770)240-7200 Fax (770)937-9107  
www.graphicpkg.com

\* Subject to product and package configurations