

领先的，不仅仅是技术……  
WE FIND WAYS...



**合肥中辰轻工机械有限公司**

**生产基地**

安徽省合肥经济技术开发区锦绣大道206号  
邮编：230601  
网址：www.hfqj.com

**中国销售**

电话：0551-62552086 / 62552089  
传真：0551-62552001  
邮箱：hfqj@263.net

**海外销售**

电话：+86-551-65210291 / 65210299  
传真：+86-551-65210290  
邮箱：infohfzc@163.com  
2012年V1.1版

**Hefei Zhongchen Light Industrial Machinery Co., Ltd.**

**Manufacturing Base**

No. 206 Jinxiu Rd., Economic and Technological Development  
Zone, Hefei City 230601, Anhui Province, China  
Website: www.hfqj.com

**Domestic Sales**

Tel: 0551-62552086 / 62552089  
Fax: 0551-62552001  
E-mail: hfqj@263.net

**International Sales**

(Central International Machinery Co., Ltd.)  
2F, 287 Qianshan Rd., Hefei City 230031, Anhui Province, China  
Tel: +86-551-65210291 / 65210299  
Fax: +86-551-65210290  
E-mail: infohfzc@163.com  
Version 1.1, 2012



- 产品样本
- PRODUCT BROCHURE
- 啤酒及相关酒类生产线解决方案
- SOLUTIONS FOR BEER & RELATED ALCOHOLIC DRINK BOTTLING/CANNING LINES





## 企业简介 Company Profile

WE FIND WAYS...

WWW.HFQJ.COM

### 领先的，不仅仅是技术.....

#### WE FIND WAYS...

合肥中辰轻工机械有限公司坐落于中国安徽合肥市国家级经济技术开发区，占地总面积近10万平方米。公司从1984年开始就专业从事饮料、啤酒灌装包装自动化生产线设备的设计开发与制造，是中国饮料装备行业的核心骨干企业。设计资质、加工手段、产品质量以及售后服务一直处于行业领先地位。中辰轻机现有员工近500人，具有高等教育背景的各类专业技术和销售人员300多人。

中辰轻机同时拥有ISO9000:2000质量管理体系认证、CE认证，并按ISO及现代企业管理机制长效流畅运营。公司具有制造一、二类压力容器的国家级资质，公司的主导产品连续获得多次专利技术认证、国家重点新产品、行业优秀供应商等殊荣。公司参与并起草了多部国家级饮料啤酒生产线行业标准规范。

中辰轻机在全球化的背景下，将奉行“忠诚、务实、高效、创新”的理念与世界先进同行在国际舞台上同场竞技，我们还愿意与一切有共同理念的企业合作，共同创造双赢，共同开创饮料、啤酒工业设备新的局面；为中外饮料、啤酒行业提供最好的解决方案和高品质的技术装备、售后服务，是中辰轻机永恒的宗旨和追求。

中辰轻机的产品系引进欧洲著名的一流公司的技术，同时结合自身多年的设计、生产及服务的经验，赢得了众多中高端著名的客户。经过多年稳步发展，中辰轻机早已成为中国首屈一指的专业研发和制造适合PET瓶、玻璃瓶、易拉罐等包装容器的饮料、啤酒等成套生产线设备和工程的高新技术企业。产品涵盖碳酸饮料生产线设备、水生产线设备、果汁茶饮料牛奶生产线设备、啤酒黄酒白酒生产线设备等以及成套整厂交钥匙工程设备。公司产品远销60多个国家和地区，在饮料行业成功地地为可口可乐、百事可乐、娃哈哈、健力宝等国内外知名企业提供了多条先进生产线设备；在酒行业成功进军嘉士伯、帝亚吉欧、燕京啤酒、青岛啤酒、华润雪花啤酒、百威英博等国内外知名企业。



### Company Profile

Hefei Zhongchen Light Industrial Machinery Co., Ltd., a first-class company in Chinese liquid-filling and packaging equipment industry, has been engaged in the design, R&D and manufacturing of complete equipment sets for beverage and beer automatic bottling line since 1984, and has taken the lead in the industry in terms of design qualification, processing capability, product quality, and after-sales service. It is located in National Economic and Technological Development Zone of Hefei City, in the Province of Anhui, which covers an area of 100,000 m<sup>2</sup>. It now has 500 employees, among which more than 300 are technical professionals and sales personnel with high education background.

With its initial technologies introduced from renowned European companies, Hefei Zhongchen Co. now manufactures high quality products based on the integration of years of experience in design, engineering, fabrication, installation, and service, which has won a number of famous high-end customers. After years of steady development, it has become a leading National High and New Tech Enterprise specialized in R&D and manufacturing of complete equipment sets for beverage and beer bottling lines and turnkey projects, including CSD / water / juice / tea drink / milk / beer / millet wine / liquor, etc. The products have been exported to more than 60 countries and regions. In the beverage industry, it has supplied complete beverage / water line equipments for Coca-Cola, Pepsi-Cola, Wahaha, Jianlibao, etc.; while in the beer industry, it has successfully provided hundreds of advanced bottling lines for Carlsberg, Diageo, Yanjing Beer, Qingdao Beer, China Resources Snow Breweries, AB InBev, etc.

Hefei Zhongchen Co. obtains the quality certifications of ISO9000:2000 and CE, and operates smoothly in accordance with ISO and modern enterprise management mechanisms. With national qualifications for designing and manufacturing first-class and second-class pressure vessels, it has received honors of patent technology certification, National Key New Products, Excellent Industrial Supplier, etc. for several times consecutively. It has participated in drafting a number of national industry standards in beverage / beer bottling lines.

In the context of globalization, Hefei Zhongchen Co. will abide by the concept of "Loyalty, Practice, Efficiency, Innovation", and compete with advanced counterparts on the global market. We are willing to cooperate with any enterprise with a common philosophy as ours to create new partnerships. Its foremost objective is to provide the best solutions, high-quality equipments and after-sales service for beverage and beer industry domestically and internationally.





# 市场 / 荣誉 Market / Honors

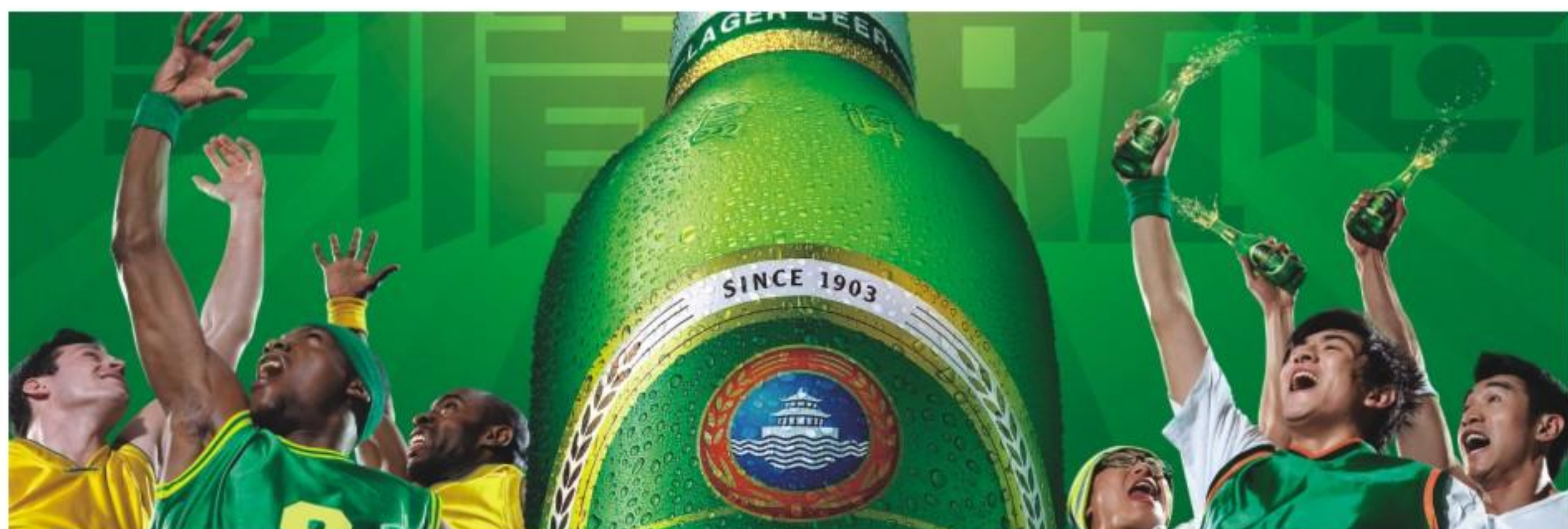

公司产品远销国内外60多个国家和地区，在啤酒行业进军嘉士伯、帝亚吉欧、燕京啤酒、青岛啤酒、华润雪花啤酒、百威英博等知名企业；在饮料行业为可口可乐、百事可乐、娃哈哈、健力宝等知名企业提供了数百条先进生产线设备；在调味品行业与海神黄酒、王致和等知名企业取得合作，与国内外众多知名企业的合作是我们产品和服务实力的最好见证。

The products have been exported to more than 60 countries and regions. In the beer industry, she has successfully provided complete bottling line equipments for Carlsberg, Diageo, Yanjing Beer, Qingdao Beer, China Resources Snow Breweries, AB InBev, etc.; in the beverage industry, has supplied hundreds of advanced beverage / water lines for Coca-Cola, Pepsi-Cola, Wahaha, Jianlibao, etc.; while in the seasoning industry, has cooperated with Hai Shen Millet Wine, Wang Zhi He, etc. Cooperation with numerous well-known enterprises is the best witness of our products and service.



公司不仅仅在技术上一直处于同行业的领跑者，得到各相关行业协会及国家各相关部门的认可与表彰。更坚持走质量效益型发展道路，规范推进国际化的先进管理体系。质量文化已经渗透到研发、生产、销售和服务的每个细节当中，成为一种自觉行为，并带领企业获得诸多荣誉，得到广大客户的一致好评与推荐。

The company not only has been the leader in terms of technology, obtaining approval and recognition from each relevant industry association and national relevant departments, but also insists to quality-oriented development road, normalize and promote international advanced management system. Quality cultures have penetrated into R&D, production, sales and service, becoming one kind of conscious behavior, and lead the enterprise to obtain many honors, high praised and recommended by most customers.

WEFINDVANS...

WWW.HFOJ.COM



- 05 玻璃瓶啤酒灌装包装生产线  
Beer Glass Bottling Line
- 17 易拉罐啤酒灌装包装生产线  
Beer Canning Line
- 19 PET瓶啤酒灌装包装生产线  
Beer PET Bottling Line
- 21 其它酒类、调味品及日化品灌装包装生产线  
Related Alcoholic Drinks, Seasoning & Daily Chemicals Bottling / Canning Line
- 24 生产线通用设备  
Common Equipments on Production Lines
- 25 我们与客户  
Together We Are Strong





## 玻璃瓶啤酒灌装包装生产线 Beer Glass Bottling Line

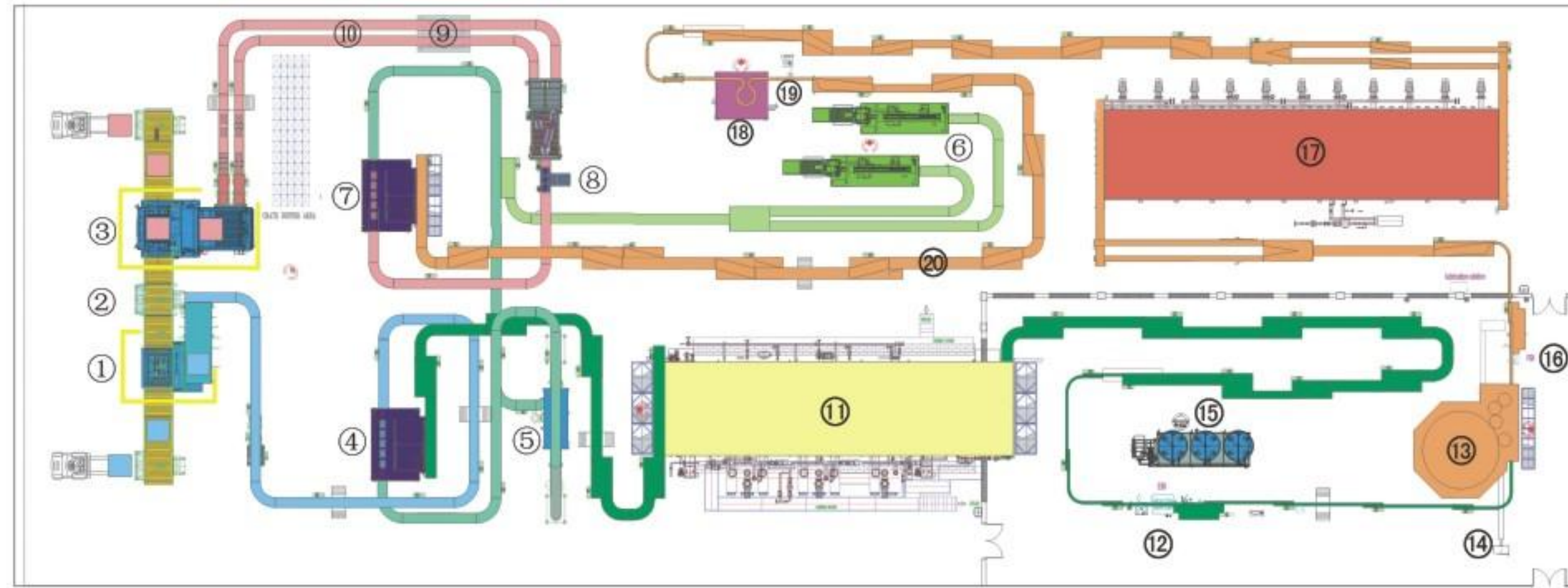

- |         |                         |          |                      |                    |
|---------|-------------------------|----------|----------------------|--------------------|
| 1.卸箱垛机  | Crate Depalletizer      | 8.满箱检测机  | FCI                  | 15.CIP             |
| 2.垛板仓   | Pallet Magazine         | 9.封箱机    | Carton Seamer        | 16.FBI             |
| 3.码箱垛机  | Crate/Carton Palletizer | 10.输箱带   | Pack/Carton Conveyor | 17.巴氏杀菌机           |
| 4.卸箱机   | Decrater                | 11.洗瓶机   | Bottle Washer        | 18.贴标机             |
| 5.洗箱机   | Crate Washer            | 12.EBI   |                      | 19.喷码机             |
| 6.纸箱成型机 | Caron Erector           | 13.灌装压盖机 | Filler & Crouner     | 20.输瓶线             |
| 7.装箱机   | Crate/Carton Packer     | 14.输盖机   | Crown Elevator       |                    |
|         |                         |          |                      | Tunnel Pasteurizer |
|         |                         |          |                      | Labeler            |
|         |                         |          |                      | Bottle Coder       |
|         |                         |          |                      | Bottle Conveyor    |

### 设备组成

包括卸箱垛机、卸箱机、洗箱机、洗瓶机、灌装压盖机、输盖机、喷码机、杀菌机、贴标机、装箱机、码垛机、实瓶输瓶系统、输箱系统、电气控制系统等在内的一整套灌装包装生产线。

### 可选设备

新瓶可选全自动卸瓶垛机，以及冲瓶 - 灌注 - 压盖三联机；干包装设备可选择纸箱或膜包类包装设备。

### Scope of Supply

Crate depalletizer, decrater, crate washer, bottle washer, filler & crouner monobloc, cap feeder, ink jet coder, tunnel pasteurizer, labeler, crater, palletizer, full bottle / pack conveyor, electrical control system, etc.

### Optional Equipments

Full-automatic bottle depalletizer, rinser & filler & crouner monobloc for new bottles, and carton / shrink film can be selected for secondary packaging.

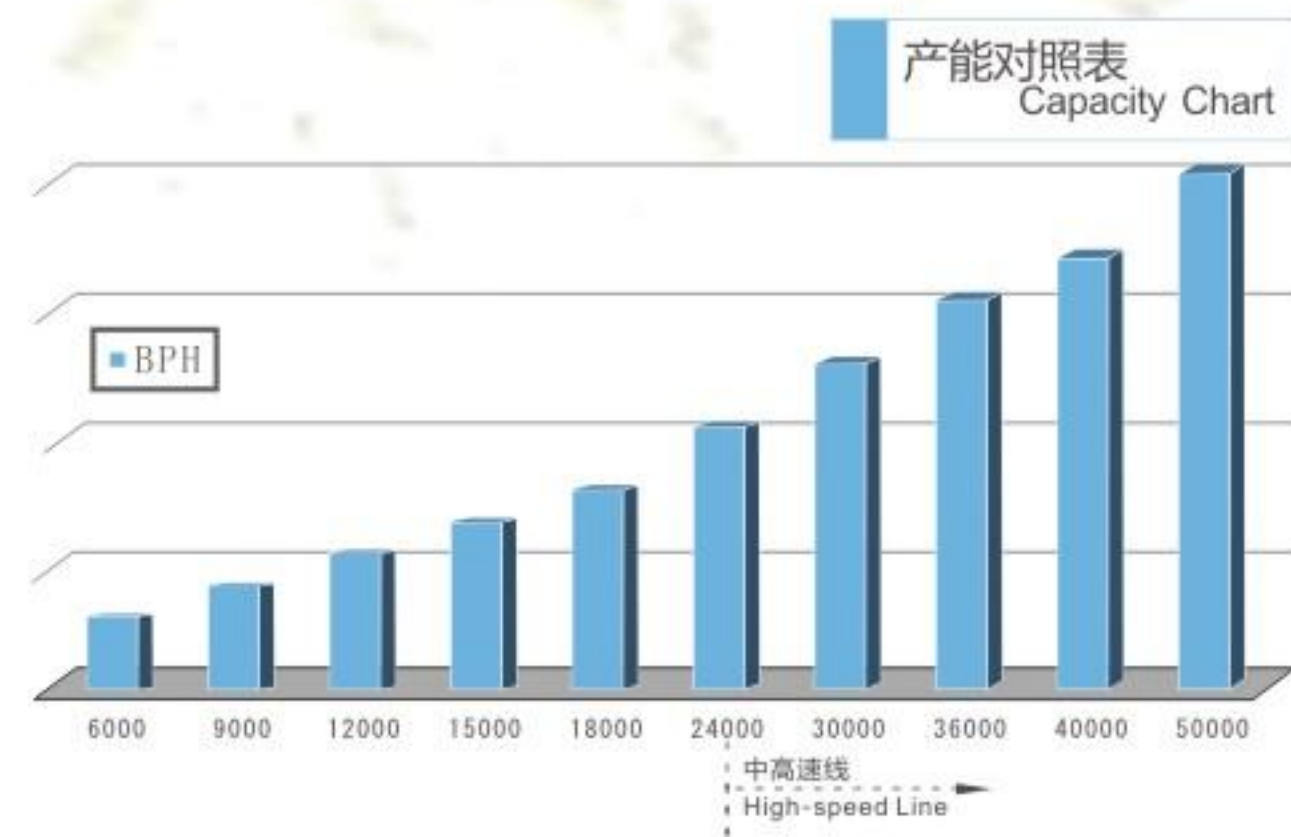

WE FINDWAYS...

WWW.HFOJ.COM



## 玻璃瓶啤酒灌装包装生产线 Beer Glass Bottling Line

### 啤酒双端洗瓶机系列一 Double-end Bottle Washer ( I )



- 本洗瓶机为双端式。进、出瓶各为一端。出瓶可封闭在灌注房内，脏瓶被拒之灌注间外，实现脏洁分流，减少净瓶污染。
- 主传动采用SEW变频电机，变频调速。设有多处过载安全保护装置，确保生产安全可靠稳定。
- 对于高速线洗瓶机，设有四、五或六个浸泡槽，多套除标装置，以及多处旋转或往复喷淋装置，确保洗净瓶子符合卫生标准。
- 采用独特设计的给瓶和卸瓶装置，操作运转平稳。载瓶架为焊接而成，载瓶盒采用全塑或钢制，适应不同的工艺要求；瓶口定位，适应瓶型多样化。
- 本洗瓶机可根据不同生产工艺，设置各槽的洗涤液浓度，方便降低消耗。同时，配置自动碱液添加系统。
- The bottle washer is double-end type, with bottle infeed and discharge at each end. Bottle discharge section can be enclosed inside the filling room, which can realize dirty and clean in separate end, to reduce pollution on cleaned bottles.
- Main drive adopts SEW product modulated with frequency conversion. Multiple safe overload protection devices are equipped to ensure production safe and reliable.
- For high speed bottle washer, four, five or six caustic soaking compartments with sufficient caustic soaking time, multiple label extractors, and multi-rotary (or reciprocating) sprinklings ensure washed bottles in accordance with sanitary standard. Smooth bottle infeed and discharge by means of proper design.
- Bottle carriers are welded and very firm, and steel pockets with plastic inserts for protection of mouth and centering of bottle (Optional: full plastic pockets).
- The caustic solution concentration is able to pre-set in each compartment as per customer requirements, and auto caustic dosing system is equipped.



玻璃瓶啤酒灌装包装生产线  
Beer Glass Bottling Line

WE FINDWAYS...



玻璃瓶啤酒灌装包装生产线  
Beer Glass Bottling Line

WWW.HFQJ.COM

啤酒双端洗瓶机系列二  
Double-end Bottle Washer (II)

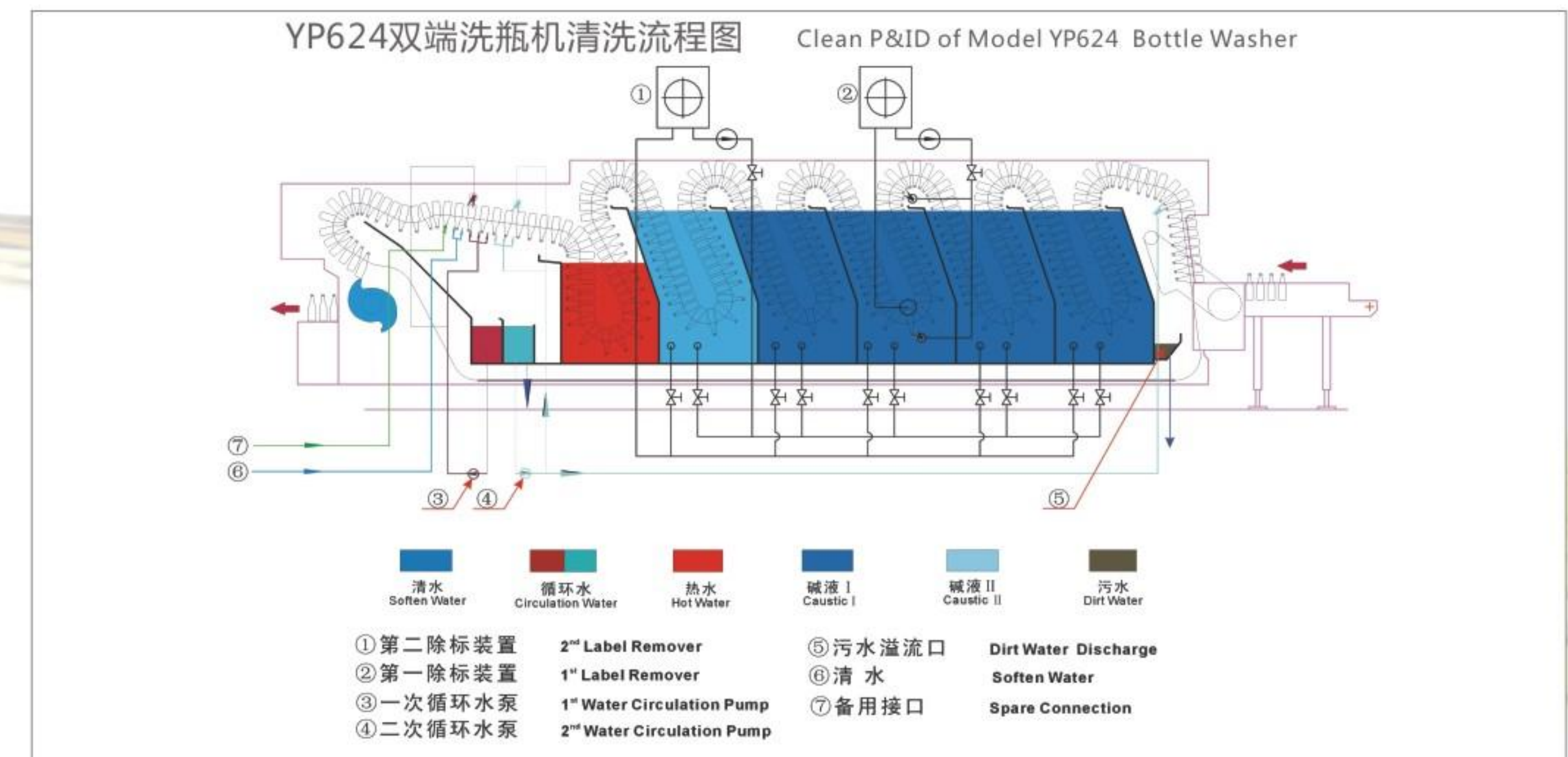
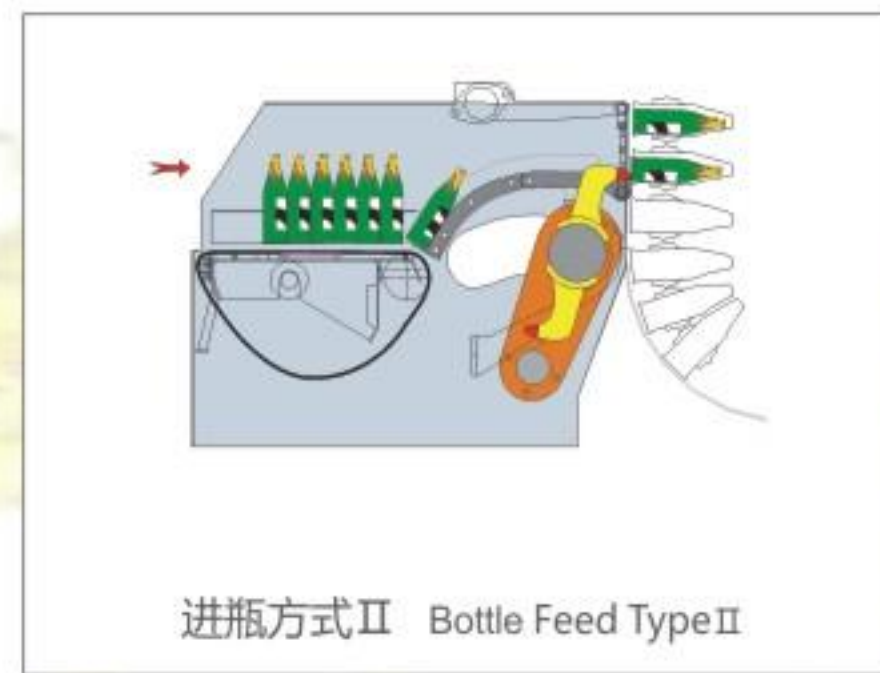
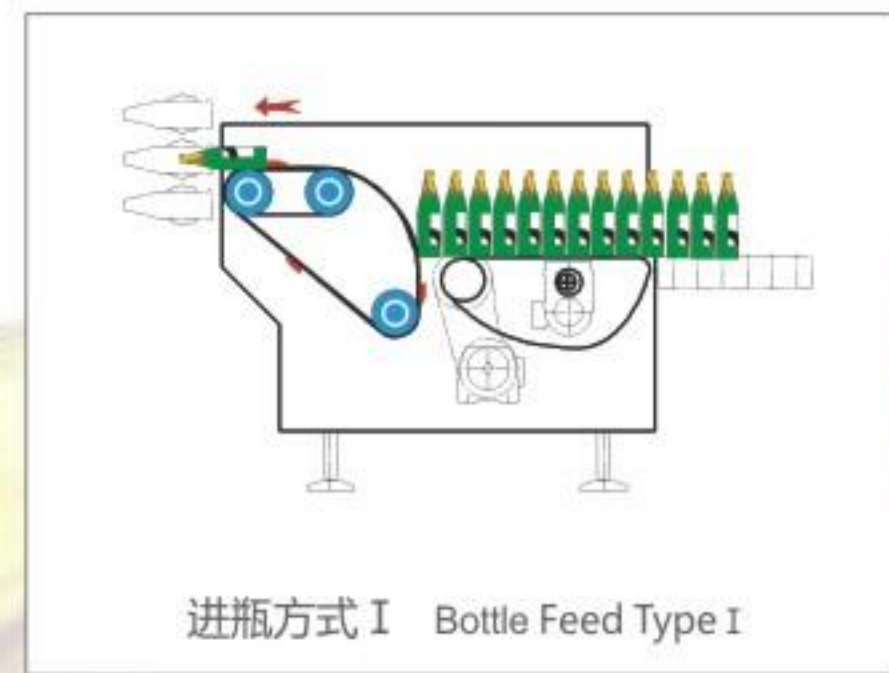
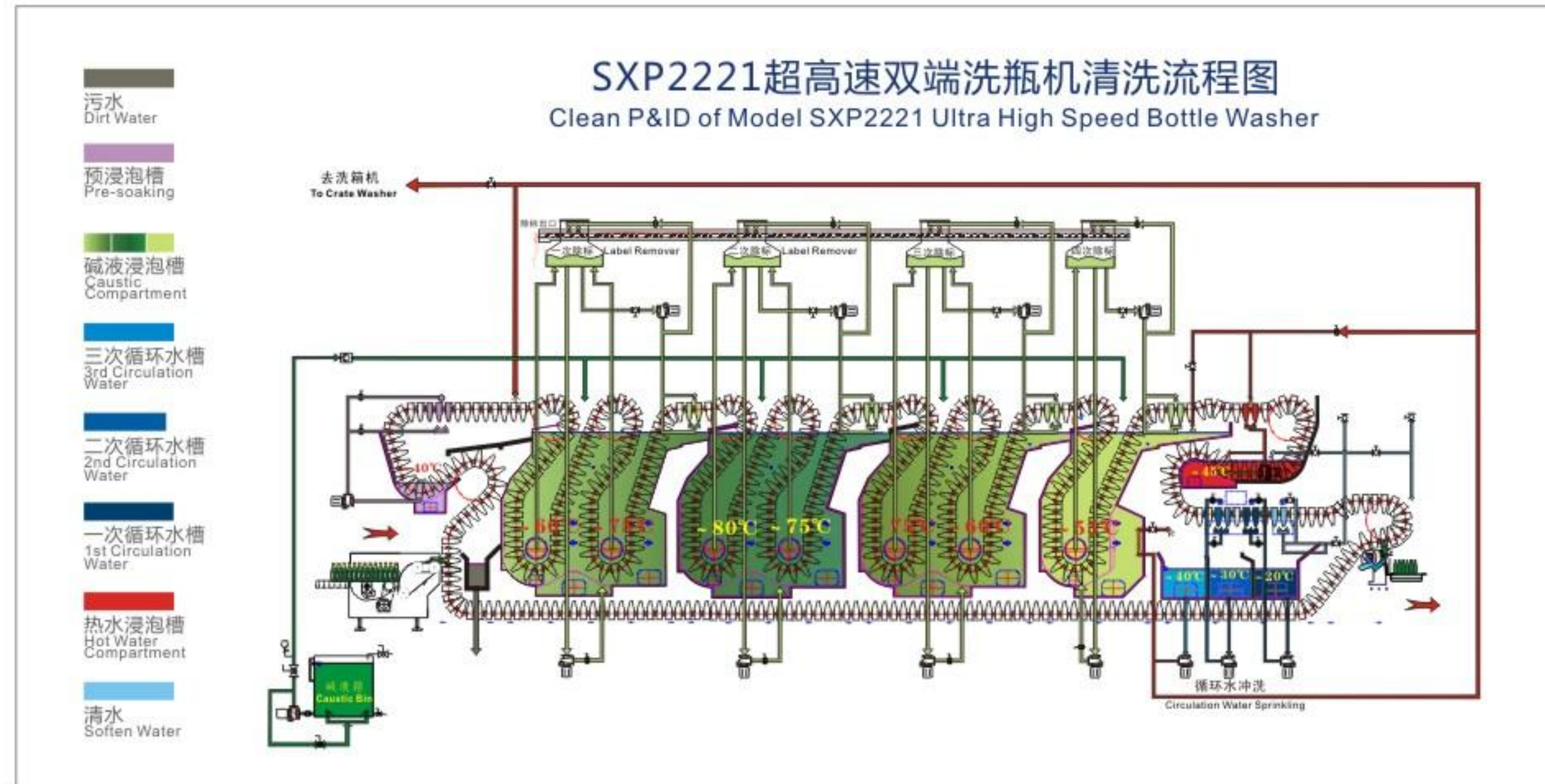



玻璃瓶啤酒灌装包装生产线  
Beer Glass Bottling Line

啤酒单端洗瓶机  
Single-end Bottle Washer

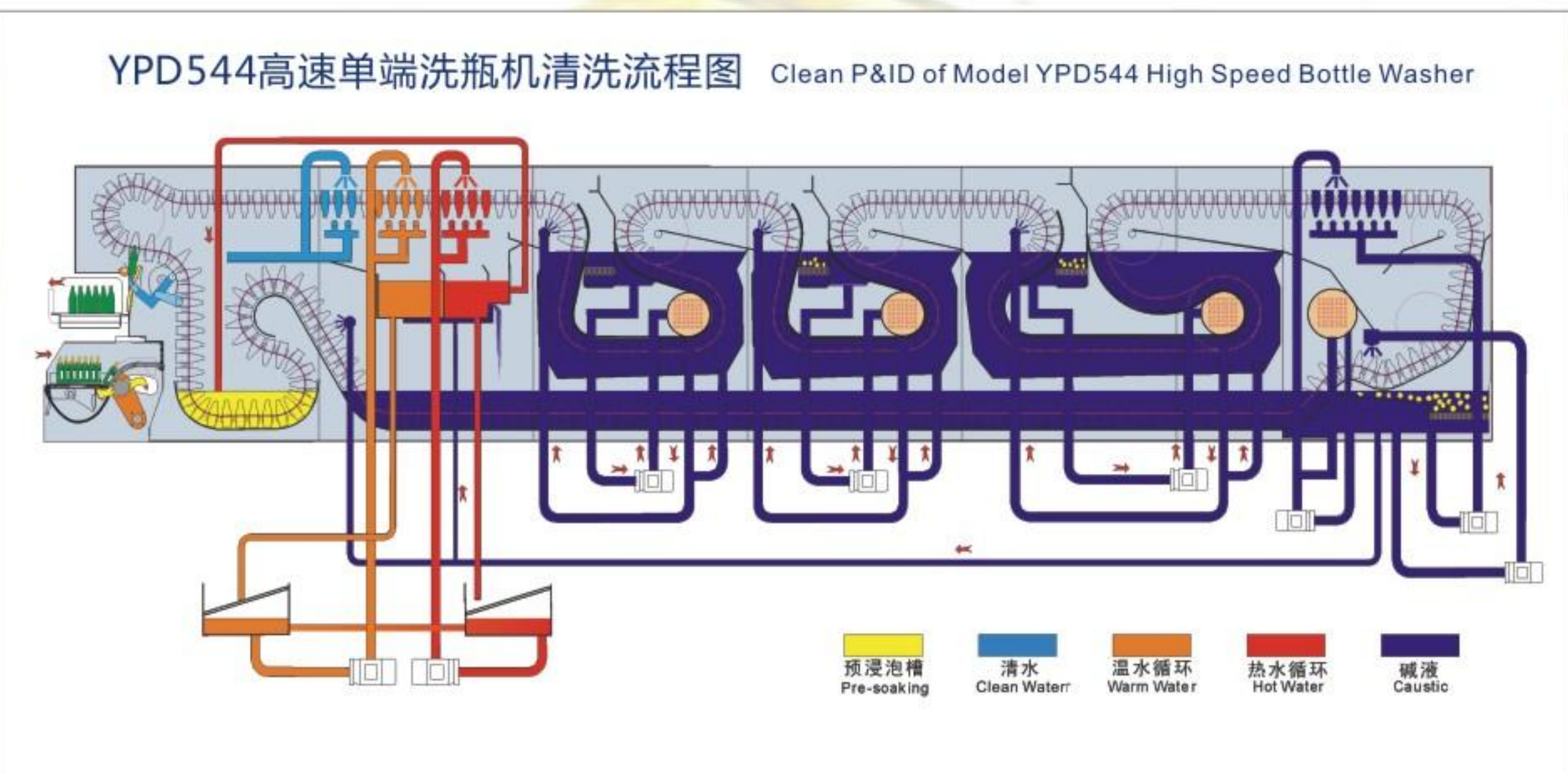

WE FINDWAYS...

WWW.HFOJ.COM



玻璃瓶啤酒灌装包装生产线  
Beer Glass Bottling Line

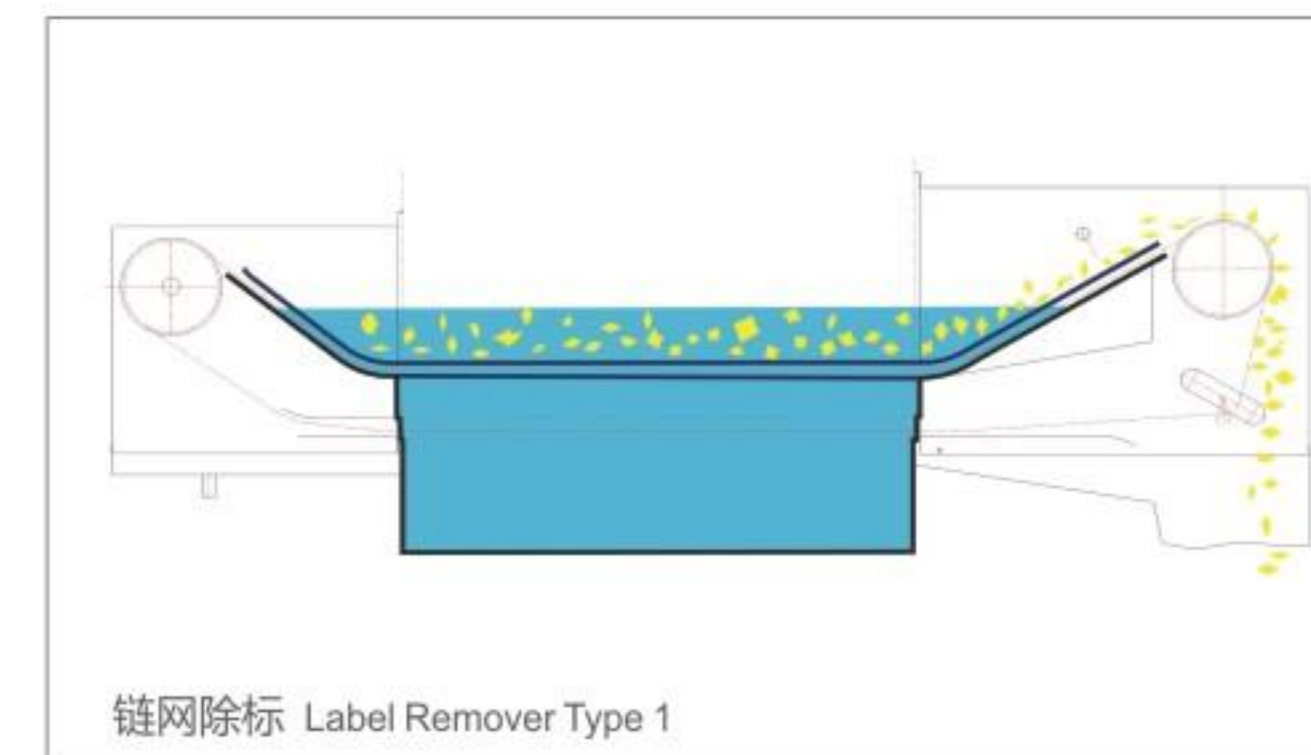
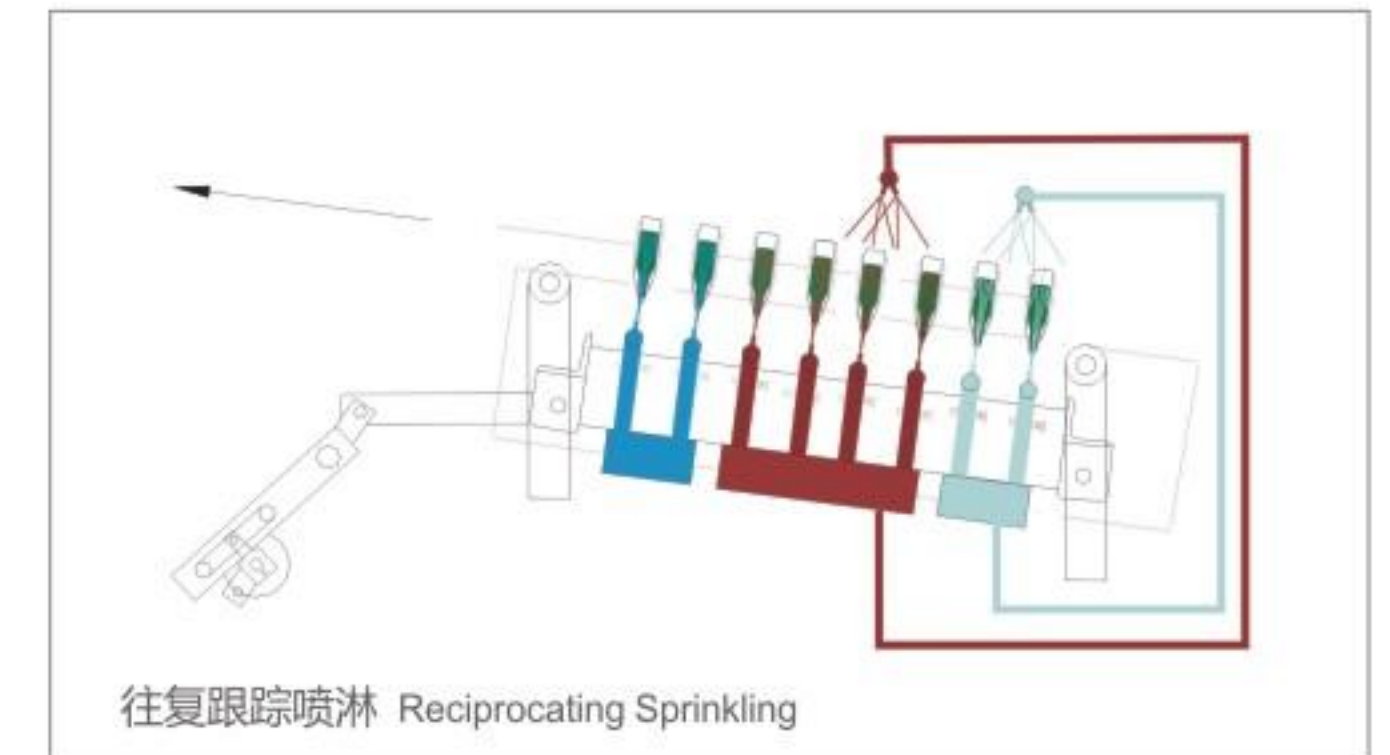
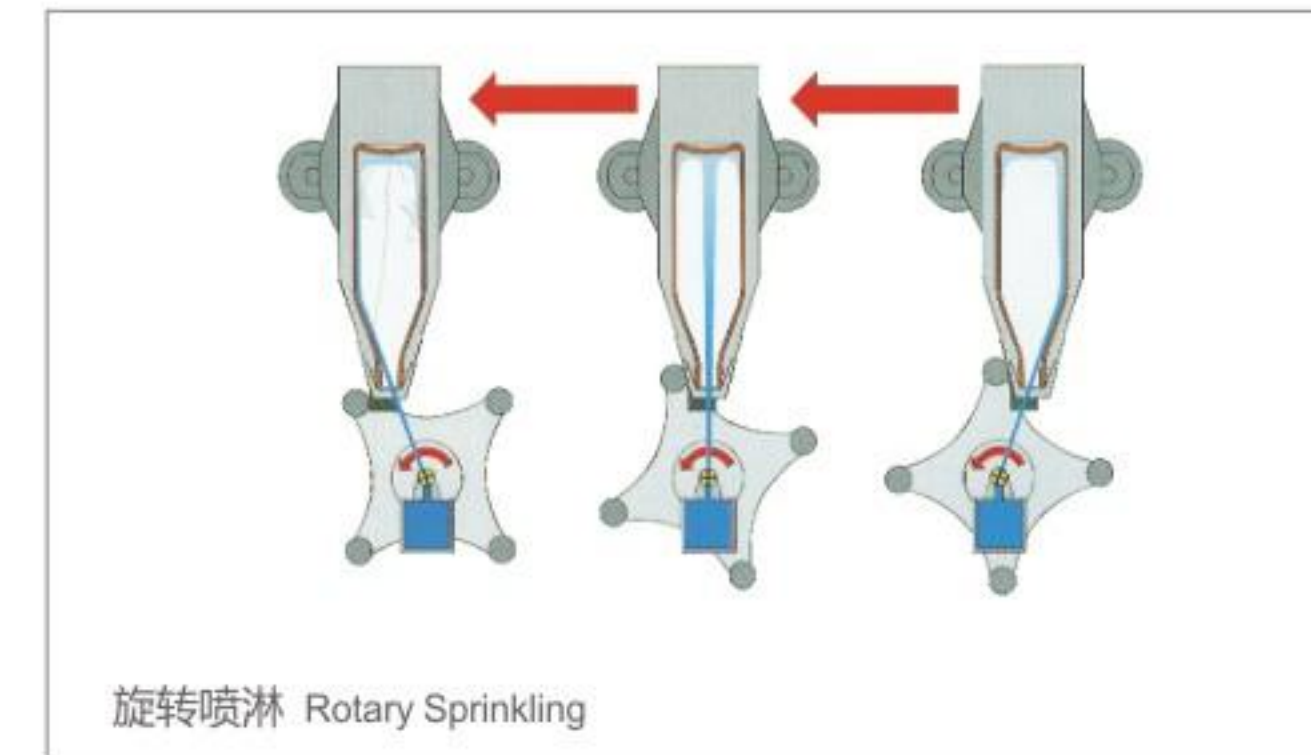

- 本系列洗瓶机进出瓶在同一端，结构紧凑，占地面积小，操作与维护方便。
- 进瓶与出瓶采用先进的回转摇摆式机构，动作平稳、噪音低。
- 多道瓶内跟踪喷淋和瓶底固定喷淋。再加上两台强力抽风机分别的吹水和干燥，能确保瓶子去除残液，符合卫生标准。
- 根据不同的产量要求，本机设有三、四或五个浸泡槽。各槽结构设计为循环加热溢流，热能利用率高，耗水小。三道除标装置，能有效地去除残标。
- 多道安全过载装置能完全保证机器的安全操作，在卡、堵瓶的情况下机器自动卸荷，故障排除后可反转自动复位。
- Bottle infeed and discharge are at the same end, with compact structure, small occupying area, convenient operation and maintenance.
- Advanced rotary swing structure infeed / discharge section, with stable operation and low noise.
- Multiple bottle inside tracking sprinkling and bottle bottom fixed sprinkling, together with two strong water removing and drying fans can ensure minimal residuals, in accordance with sanitary standard.
- Three, four or five caustic soaking compartments and three label extractors as different capacity requirements.
- Multiple overload protection devices can completely ensure safe operation, automatically unload in case of bottle block and jam, and automatically reset after clearing of fault.



# 玻璃瓶啤酒灌装包装生产线 Beer Glass Bottling Line

WE FINDWAYS...

WWW.HFJL.COM

## 灌装压盖机 Beer Filler&Crownner

- 短管式二次抽真空并以CO2或氮气作为背压的灌装工艺；高精度机械灌装阀，具有无瓶不抽真空、不灌装功能。
- 酒缸底座、工作台采用流线型钢板焊接结构，倾斜式保洁平台；灌装台上碎瓶清理喷冲（吹）装置；酒缸、控制环与压盖头具有自动升降功能。
- 主传动系统采用悬吊式齿轮传动，采用变频同步调速技术；卫生型导瓶装置，一体式导瓶星轮，开放式导瓶板，流线型支撑件；带滚轮导杆升降式具有预定中功能的定中装置；旁挂式托瓶气缸。
- 压盖头内部采用进口自润滑复合材料导向套；托瓶座上有压盖压力补偿装置。
- 配备进口高压激泡装置，利用细流热无菌水（85℃）激泡，激泡压力与主机速度同步调节（分级调压）。
- 配置纳西姆真空泵，具有循环水温控制装置（配不锈钢循环水罐），保证真空度（真空度≤ - 0.085Mpa）。
- 配备CIP清洗杯，实现灌注机循环清洗；开放式阀站管路系统，能按照设置的程序自动进行逐个通道进行清洗。
- 可由编程控器完成灌装、破瓶喷冲、酒缸回气管启闭、高压激泡、瓶盖搅拌、吹气入盖、缺盖显示、整机润滑等整个生产过程的自动控制，操作显示由先进的人机界面实现；设备根据进出瓶带上瓶的满缺，按设定速度全速或慢速运行，进瓶挡瓶，无瓶不开阀、不下盖，爆瓶自动冲洗，灌装速度显示，灌装瓶数累计。

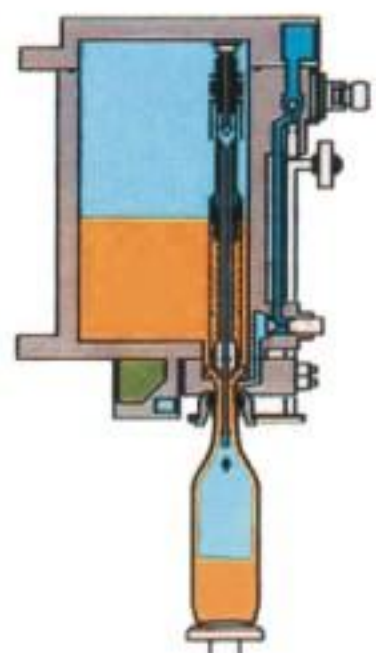

灌注系统示意图  
Filling System Sketch Map



# 玻璃瓶啤酒灌装包装生产线 Beer Glass Bottling Line



- Short tube high accuracy mechanical filling valve with double pre-evacuation; Adopt CO2 or nitrogen as counter pressure gas, no bottle no pre-evacuation & no fill.
- Streamline welded filler platform with sanitary bedplate; Burst bottles flusher; Filling bowl / control mechanism / crownner have auto elevating features.
- Suspension type main gear drive with VSD control; sanitary bottle guiders, intergrated bottle star wheels & open type bottle guiding plates; Centering devices with pre-centering by means of lifting guide poles with rollers; Side hanging bottle lifting cylinders.
- Interior guiding sleeves of crowning heads adopt imported lubrication free material guiding sleeve; Crowning pressure compensation devices on bottle lifting pads.
- Equipped with imported high-pressure bubbler, bubbling with 85℃ hot sterilized water, and bubbling pressure is sync control with filler speed.
- Nashi brand vacuum pump with S.S water circulation tank features water temperature circulation controlling to guarantee vacuum degree ≤ - 0.085Mpa.
- Circulation CIP of filler with dummy cups, the channels are cleaned in sequence as per programs by means of open type valves / pipings station.
- Filling, burst bottles flushing, open&close of bowl gas vent tube, high-pressure bubbling, caps stirring, capping blow & feeding, display of cap lack, and machine lubrication, etc. are well auto-controlled via PLC & displayed on HMI. The machine speed is regulated as per bottle quantity signals from infeed / discharge conveyors, equipped with bottle infeed stopper, no bottle no filling & no capping, filling speed display & counter of filled bottles, etc.



# 玻璃瓶啤酒灌装包装生产线 Beer Glass Bottling Line

WE FINDWAYS...



# 玻璃瓶啤酒灌装包装生产线 Beer Glass Bottling Line

## 巴氏隧道杀菌机 Beer Tunnel Pasteurizer

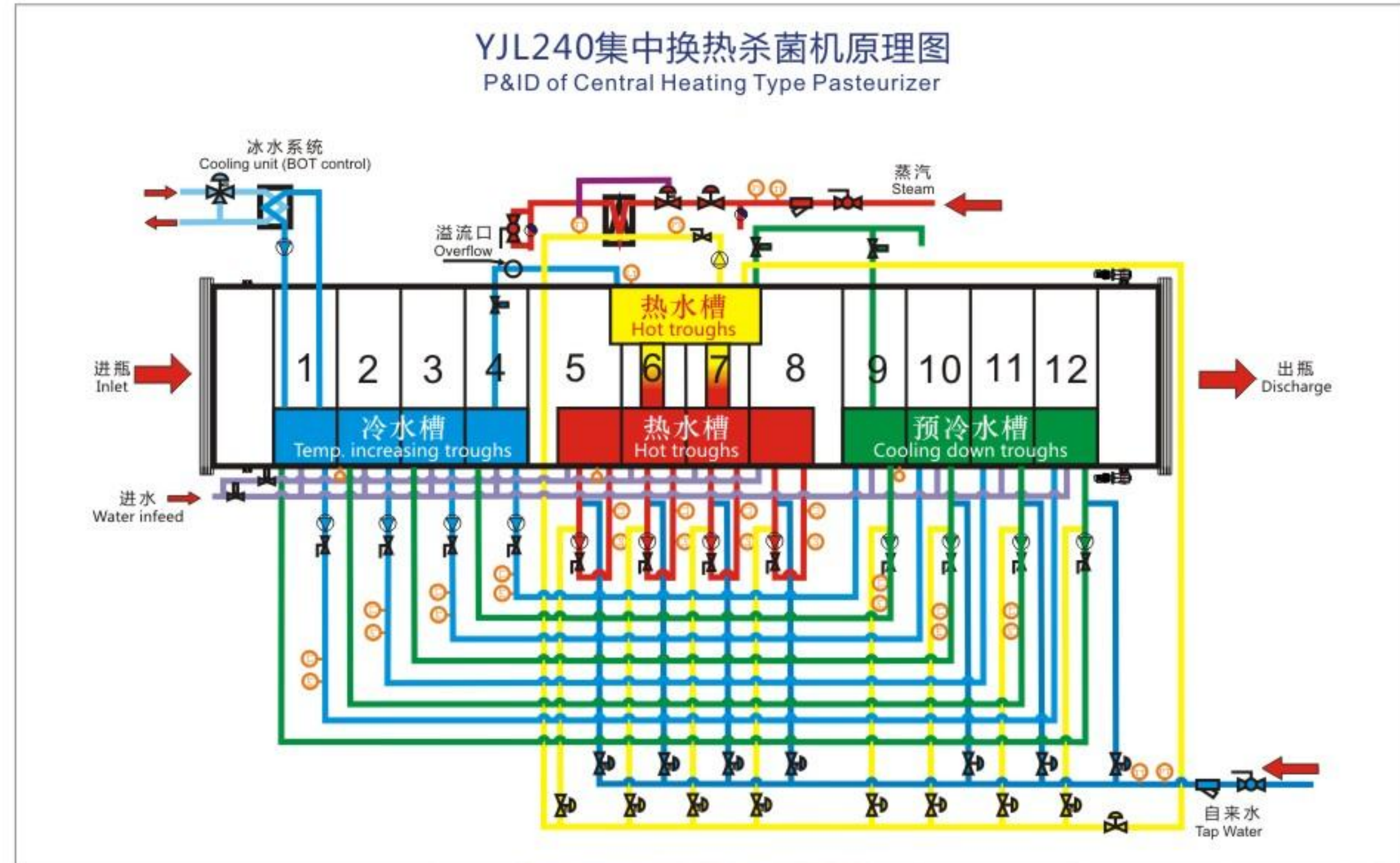

WWW.HFQJ.COM



Tunnel Pasteurizer is mainly to pasteurize the beer / beverage products after filling. The machine can continuously sprinkle, warm up, pasteurize, and cool down the bottled / canned beer or beverage to achieve proper pasteurizing effects.

The machine is made of full stainless steel frame with compact structure and convenient maintenance. Double deck design is applied in middle & high capacity bottling line. The chain mesh is made of full stainless steel or engineering plastic type according to applications. Overcurrent protection and mechanical overload protection are installed to protect the machine.

- Water / heat recovery technology is equipped in warming up, pasteurizing, and cooling with water and heat saving features. The system will normally have 8 to 12 temperature zones, and the centralized heat exchanging design can be adopted.
- Less temperature gradient not only guarantees good pasteurizing effect, but also decreases bottle breakage rate. Temperature zones are established by means of sprinkling pipes with rectangular nozzles or orifices which are not easily blocked, and easily to dismount for clean & maintenance by adopting fast plug-in structure.
- Auto PU control system is realized. The main drive will auto stop in case of bottle discharge jam. In prolong stoppage, the high temperature zone and heat preservation zone can automatically drop the temperature below proper temp. to avoid over PU value.

本系列杀菌机为连续式喷淋，升温、杀菌、冷却的杀菌设备。主要用于各种瓶装/罐装啤酒、饮料灌装后的杀菌。

- 本机采用全不锈钢框架式设计，结构简洁，维护方便，对于中高线采用双层结构。链网可采用全不锈钢链网或工程塑料链网。本机设有电流过载保护和机械过载保护，可防止因过载而造成对设备的损害。
- 采用循环温水预冷、循环热水喷淋杀菌、循环冷水冷却等多段处理，节水、节热。系统一般为8-12个温区的设计，可采用节能型集中换热系统。
- 温差梯度小，既能保证良好的杀菌效果，又可减小破瓶率。温区的建立，采用方管方孔或孔板淋水方式，保证了温度要求又不易堵塞，而且在结构上采用易拆卸的插接式，有利于水管的清洗和维护。
- 真正的PU值控制系统。出瓶输送带堵塞时，主机减速机自动停止运转。当停机时间过长，高温区和保温区的水温会自动下降至适合温度以下，防止箱体中的啤酒因停机时间过长而导致PU值升得过高。

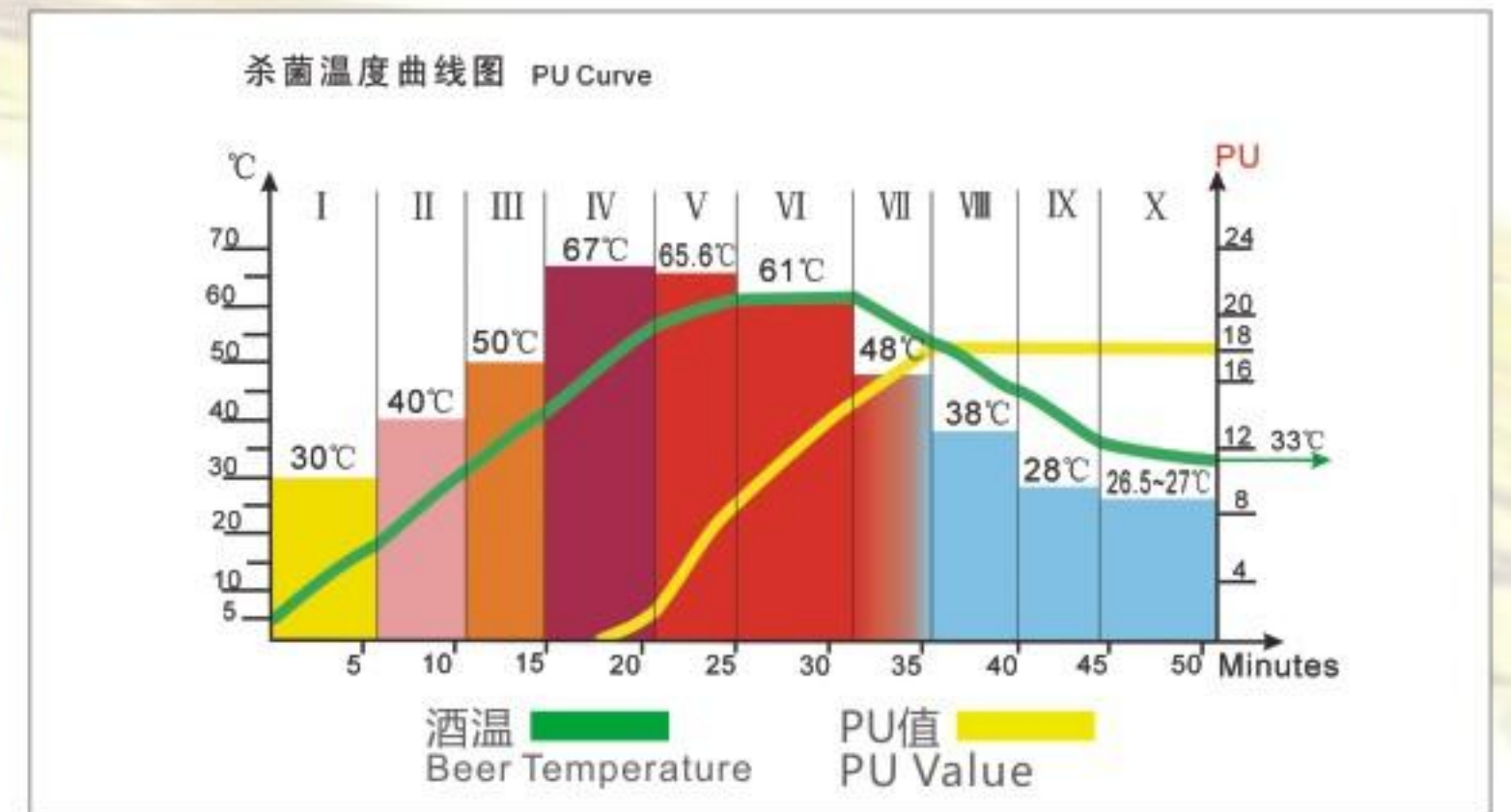



01

中辰轻机  
HEFEI ZHONGCHEN

## 玻璃瓶啤酒灌装包装生产线

### Beer Glass Bottling Line

#### 装（卸）箱机 Crater / Decrater

- 装（卸）箱机将采用平移式双轴伺服传动系统，结构简单，动作平稳，噪音更低，操作维护简便，安全性很高。抓头的水平及垂直运动，均采用伺服电机驱动同步皮带（或齿轮齿条）带动，从而实现瓶子垂直装（卸）箱，抓头持久耐用。
- 采用人机界面功能，多种瓶型随意更换，纸/塑装箱随意选择。相关参数可直接在人机界面进行坐标输入。
- 输瓶/输箱链带传动均采用变频调速，动作连贯。排箱方式采用两组箱分开定位，对箱子的尺寸要求更低。
- 独立的摇瓶及排瓶机构，结构合理。
- 整机气动装置均为无油润滑，洁净卫生。



- The crater / decrater adopts translation type double-shaft servodrives system, with simple structure but stable operation, less noise and easier maintenance. Horizontal and vertical motions of bottle grippers are realized by synchronous belts (or pinions and racks) driven by the servo motors, so as to vertically crate/decrate very smoothly with longer bottle grippers life.
- High automation control by HMI, convenient for package changeover. Relevant parameters can be coordinately input on HMI.
- Bottle conveyor and crate conveyor installed are both modularly controlled by inverters to achieve consistent motions. Crates orientation has less requirements on crates size disuniform by means of two groups of crates orientation separately.
- Independent bottle waver and bottle arranging, reasonable structure.
- All pneumatic devices are oil-free lubrication, sanitary and clean.



YZ(C)X3装（卸）箱机  
YZ(C)X3Crater / Decrater

WE FINDWAYS...

WWW.HFOJ.COM

01

中辰轻机  
HEFEI ZHONGCHEN

## 玻璃瓶啤酒灌装包装生产线

### Beer Glass Bottling Line

#### 洗箱机 Crate Washer



- S型隧道式结构，机体为全不锈钢结构。
- 自动温度控制系统。
- 在加热槽可采用洗瓶机循环水进行箱子的清洗喷淋，降低水耗。
- 在出箱端采用清水喷淋。
- 清洗喷淋管支架易于拆除。
- S-type tunnel structure, and the machine frame is made of full stainless steel.
- Automatic temperature control.
- To use filtered bottle washer discharge water in the heated compartment.
- Rinse with fresh water at discharge.
- Easy removable spray racks. Cleaning openings in each compartment.



# 易拉罐啤酒灌装包装生产线 Beer Canning Line



### 设备组成

包括全自动卸罐机、冲罐机、灌装封盖机、巴氏杀菌机、储罐台、喷码机、液位检测机、全自动纸箱包装机、实罐输罐系统、输箱系统、电气控制系统等在内的一整套灌装包装生产线。

### 可选设备

收缩膜包装机等。

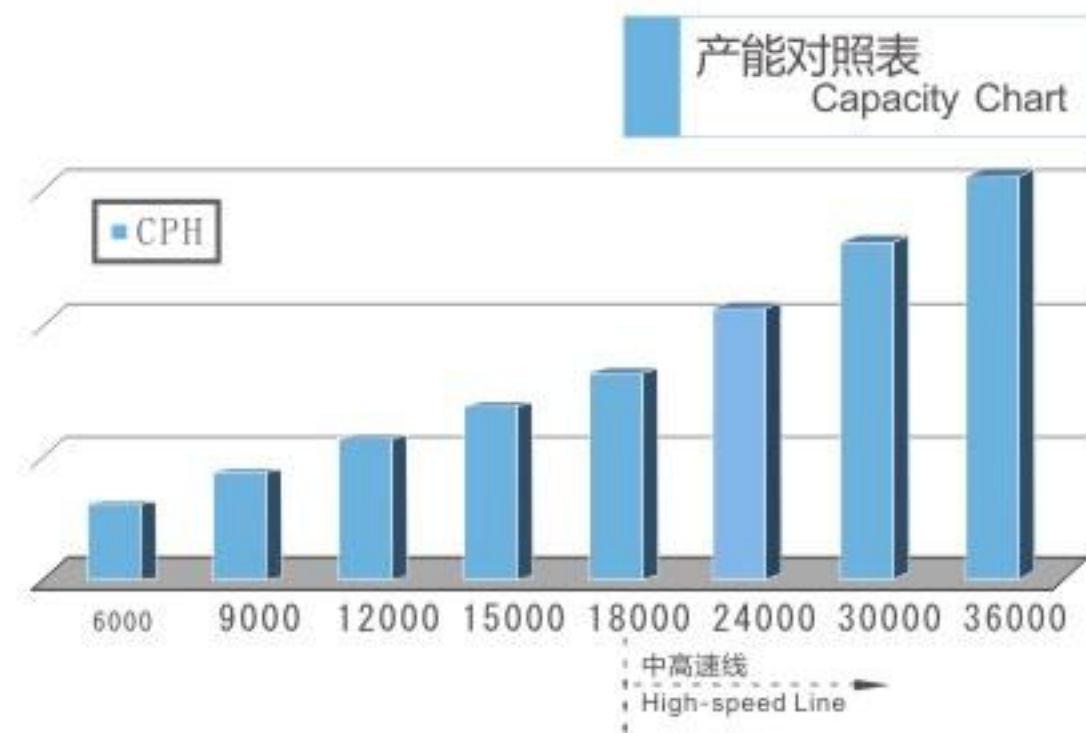

WE FINDWAYS...

WWW.HFQJ.COM



# 易拉罐啤酒灌装包装生产线 Beer Canning Line



### Scope of Supply

Automatic bulk can depalletizer, can rinser, filler & seamer, tunnel pasteurizer, buffer table, ink jet coder, level detector, full-automatic carton packer, can / pack conveyor, electrical control system, etc.

### Optional Equipments

Shrink film packer, etc.





# PET瓶啤酒灌装包装生产线 Beer PET Bottling Line



PET啤酒瓶具有重量轻、强度大、韧性好、不易破碎等优点，而且容易制作成各种规格和形状；对消费者而言，PET啤酒既适合携带，又不会产生爆炸等意外伤害。

PET beer bottle has the advantages of light weight, strong strength, good toughness and nonbreakable, and can be easily shaped into various sizes and shapes. For consumers, PET beer bottle is not only easy to carry, but also free from explosion, etc.

### 设备组成

包括吹瓶机、风力输送线、输盖机、冲瓶灌装拧盖三联机、瞬时杀菌机、贴标机、喷码机、收缩膜包装机、码垛机、缠绕机、实瓶输瓶输箱系统、电气控制系统等在内的一整套灌装包装生产线。

### 可选设备

自动理瓶机或人工理瓶系统、全自动卸瓶机、巴氏杀菌机、纸箱包装机等。

### Scope of Supply

Blow moulder, air conveyor, cap feeder, rinser & filler & capper monobloc, HTST, labeler, ink jet coder, shrink film packer, palletizer, stretch wrapper, full bottle / packer conveyor, electrical control system, etc.

### Optional Equipments

Automatic / manual unscrambling system, full-automatic bottle depalletizer, tunnel pasteurizer, carton packer, etc.

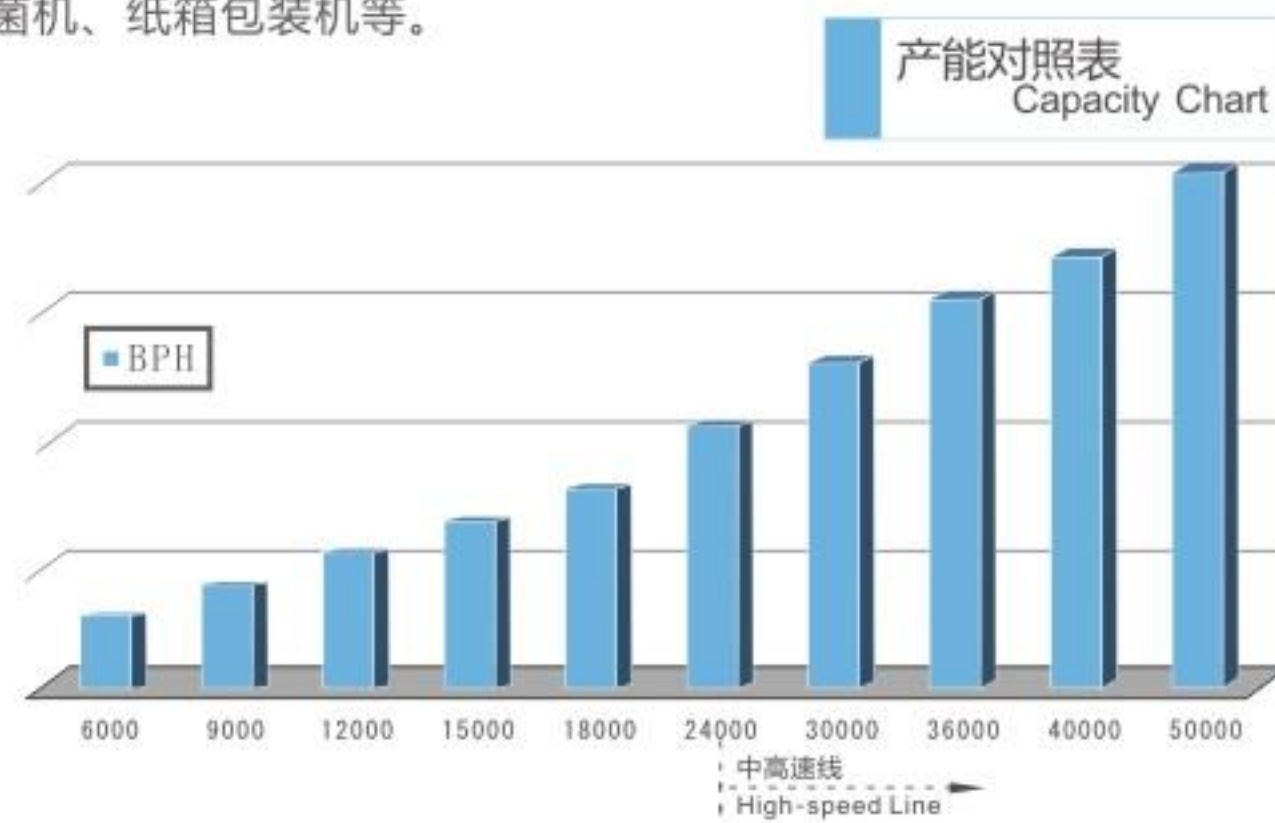

WE FINDWAYS...

WWW.HFOJ.COM



# PET瓶啤酒灌装包装生产线 Beer PET Bottling Line



### PET瓶灌装步骤 Filling Steps of PET Bottle

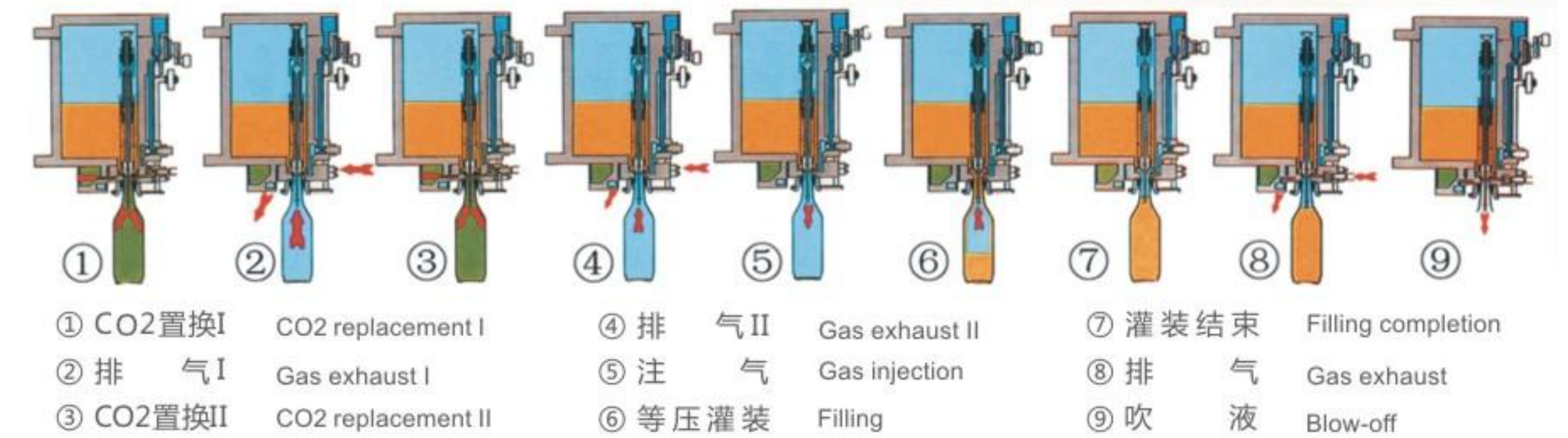

04

中辰轻机  
HEFEI ZHONGCHEN

其它酒类、调味品及日化品灌装包装生产线  
Related Alcoholic Drinks, Seasoning & Daily Chemicals Bottling / Canning Line

WE FINDWAYS...

WWW.HFQJ.COM



成功为海神黄酒集团、上海巴克斯、DIAGEO洋酒集团提供过中高速黄酒、白酒、汽酒等包装生产线的基础上，中辰轻机已经形成了完整的黄酒、白酒、汽酒、酱油、醋、油、日化品等系列化生产线产品。

Based on the successful experience in Haishen Millet Wine, Bacchus and Diageo, Hefei Zhongchen Co. has formed full series of production lines for millet wine, spirits, sparkling wine, soy sauce, vinegar, oil, daily chemicals, etc.

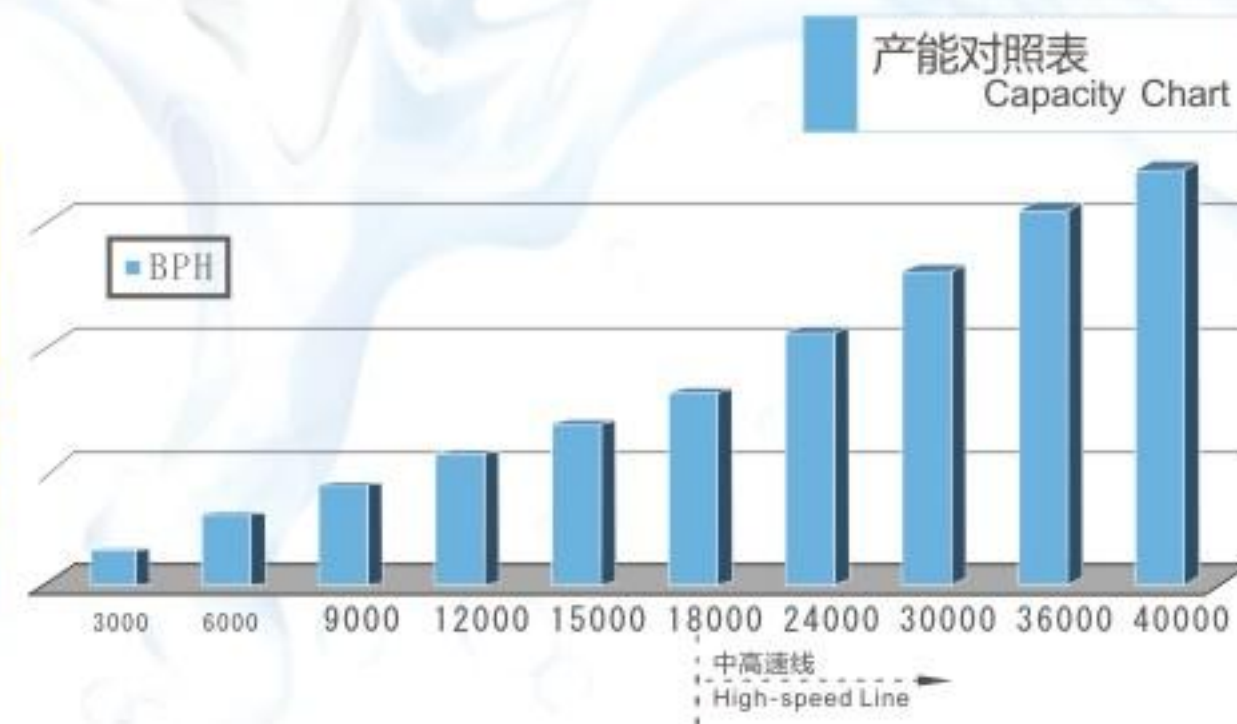

04

中辰轻机  
HEFEI ZHONGCHEN

其它酒类、调味品及日化品灌装包装生产线  
Related Alcoholic Drinks, Seasoning & Daily Chemicals Bottling / Canning Line

白酒灌装包装生产线 Spirits Bottling Line

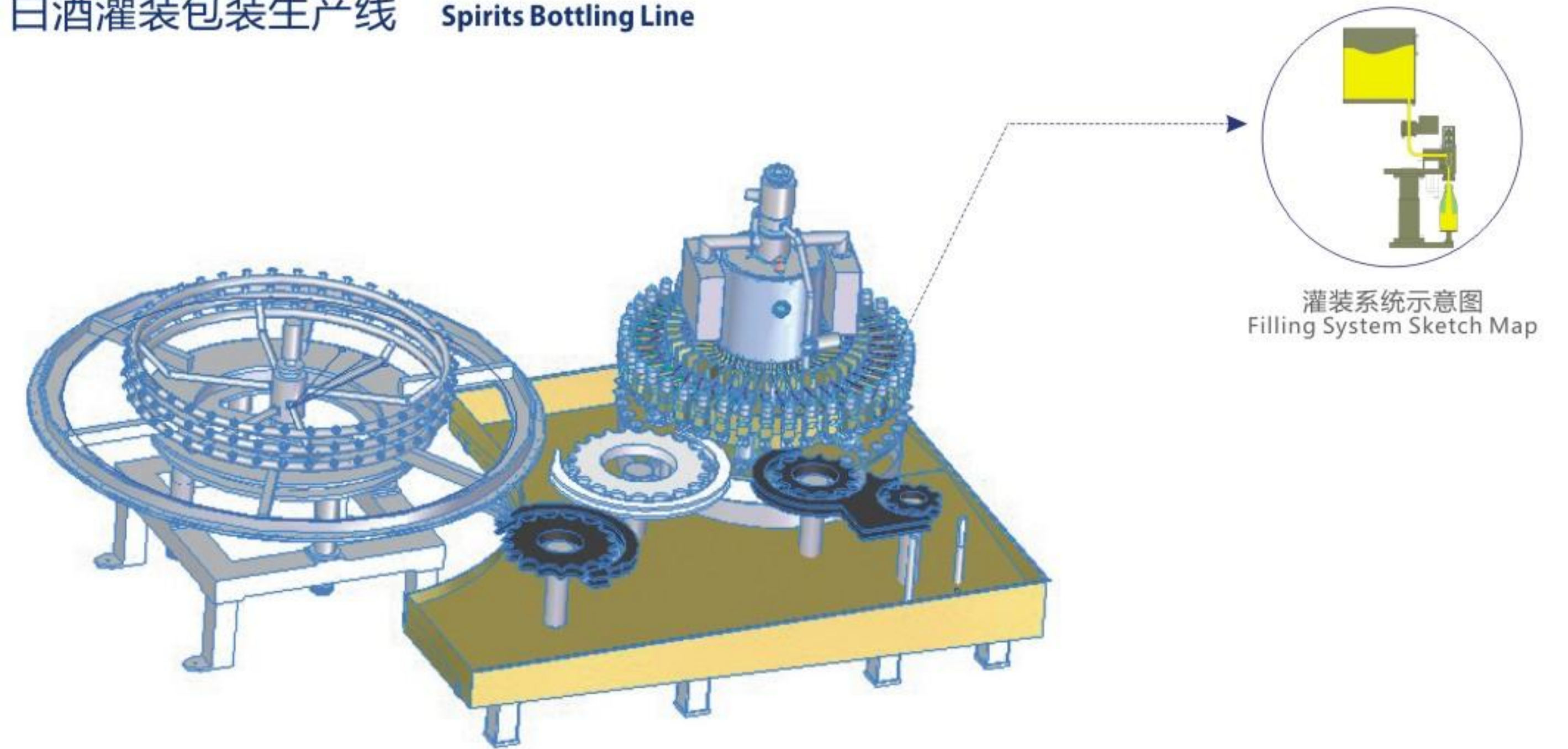

- 白酒生产线主要由上瓶、洗瓶、冲瓶灌装封盖、吹干、检验、喷码、贴标、装盒、装箱、码垛等工序组成。
- 流量计型白酒冲瓶灌装封盖三联机是一款基于本公司电子流量计灌装技术在饮料、啤酒行业的最新应用上开发的一款替代进口、实现高端白酒量产化的最佳装备，同比欧洲机器，节约了大量的投资成本。
- 本机为冲瓶灌装封盖组合机，占地少，只需一个操作者。
- 冲瓶机为电子阀双通道冲瓶，分RO水冲洗，无菌空气吹干，冲洗和吹干时间可在线设定。
- 灌装机为电子流量计式灌装，每个灌装阀可在线修正灌装容量，保证灌装精度偏差在±1.0ml以内；灌装阀防滴漏设计，灌装过程中，酒液不会滴到工作台；采用快慢灌技术，保证灌装精度；灌装缸内和阀头部位有负压抽吸装置，防止酒精气外溢。
- 封盖部分根据客户的盖型可采用自产或进口，采用水洗盖或静电除尘方法，去除吸附在盖上的灰尘和异物。
- The spirits bottling line mainly includes bottle infeed, washing, rinser-filler-capper, blow off, inspection, coder, labelling, inner packing, carton packing, palletizing, etc.
- Flowmeter type spirits rinser-fill-capper is the best & latest technology application of Hefei Zhongchen to realize accurate high speed filling.
- Less space occupation and one operator needed.
- Rinser with multiple channels controlled by E-valve to realize water rinse & aseptic air dry & clean.
- The filling valve is flowmeter type to ensure the accurate filling within ±1.0ml; Anti-drop design to avoid product waste; Safety design with negative pressure inside filling bowl and valve head parts to prevent spirits escape.
- Imported or Hefei Zhongchen made capper parts with cap water wash & air dry or static dust catcher to clean the caps.

04

中辰轻机  
HEFEI ZHONGCHEN

### 其它酒类、调味品及日化品灌装包装生产线 Related Alcoholic Drinks, Seasoning & Daily Chemicals Bottling / Canning Line

WE FINDWAYS...

WWW.HFQJ.COM

#### 黄酒、酱油、醋等灌装包装生产线 Rice Wine, Soy Sauce & Vinegar Bottling Line



根据不同产品的特性，选择合适的灌装温度。

对于黄酒灌装，洗净的瓶子，先经过暖瓶机将瓶子温度升高到50℃以上，经过进瓶螺杆、星轮进入灌装机，托瓶装置将瓶子抬起，顶开灌装阀开始灌装。瓶内的气体经过回气管回到灌装缸。灌装量会稍多于额定容量，再经过负压液位校正使瓶内的液位精确一致；也适合异型瓶子的灌装。

Filling temperature as per products requirement.

Rice wine filling: The washed glass bottles are heated to 50 °C above, then filled. The negative pressure to correct the filling level.



05

中辰轻机  
HEFEI ZHONGCHEN

### 生产线通用设备 Common Equipments on Production Lines

空瓶检测 EBI



输瓶系统 Bottle Conveyors



贴标机 Labeler



卸（码）箱垛机 Depalletizer/Palletizer



输箱系统 Carton / Crate Conveyors



管道和桥架 Pipings / Wirings



06 中辰轻机  
HEFEI ZHONGCHEN

我们与客户  
Together We Are Strong



WE FIND WAYS...

WWW.HFOJ.COM

06 中辰轻机  
HEFEI ZHONGCHEN

随处记  
Notes

Lined area for notes with horizontal lines.